

HP Archive

This vintage Hewlett Packard document was preserved
and distributed by

[www. hparchive.com](http://www.hparchive.com)

Please visit us on the web !

On-line curator: Glenn Robb

This document is for FREE distribution only!

OPERATING MANUAL
PLUS
SERVICE MANUAL

MODEL 300A
HARMONIC WAVE
ANALYZER

This is a combined Operation, Instruction, and Service Manual for all  Model 300A Harmonic Wave Analyzers. This manual contains complete operation and servicing instructions for the 300A and may be used in place of the Instruction and Operating Manual originally supplied with each instrument.

Copyright 1956 by Hewlett-Packard Company

The information contained in this booklet is intended for the operation and maintenance of Hewlett-Packard equipment and is not to be used otherwise or reproduced without the written consent of the Hewlett-Packard Company.

HEWLETT-PACKARD COMPANY
PAGE MILL ROAD, PALO ALTO, CALIFORNIA, U.S.A.

MODEL 300A HARMONIC WAVE ANALYZER
INSTRUCTION & OPERATING MANUAL

TABLE OF CONTENTS

SECTION I		<u>Page</u>
GENERAL		
1-1	GENERAL DESCRIPTION	III
1-2	SPECIFICATIONS	III
SECTION II		
OPERATING INSTRUCTIONS		
2-1	230 VOLT OPERATION	III
2-2	CONTROLS & TERMINALS	IV
2-3	OPERATION	IV
2-4	CALIBRATION ADJUSTMENT PROCEDURE.	IV
2-5	MEASUREMENT PROCEDURE.	IV
2-6	MEASUREMENT PRECAUTIONS	V
2-7	SELECTIVITY	V
SECTION III		
CIRCUIT DESCRIPTION		
3-1	GENERAL	VI
SECTION IV		
MAINTENANCE		
4-1	CABINET REMOVAL	VII
4-2	TUBE REPLACEMENT	VII
4-3	LOCAL OSCILLATOR AMPLITUDE ADJUSTMENT.	VII
4-4	VOLTAGE REGULATOR ADJUSTMENT.	VII
4-5	HUM BALANCE ADJUSTMENT.	VII
4-6	BALANCED MODULATOR ADJUSTMENT	VII
4-7	SELECTIVE AMPLIFIER ADJUSTMENT	VII
SECTION V		
TABLE OF REPLACEABLE PARTS		
5-1	GENERAL	VII

THE ATTACHED 300A-2 SERVICE MANUAL HAS A SEPARATE INDEX APPEARING ON PAGE I.

INSTRUCTION & OPERATING MANUAL

SECTION I

GENERAL

1-1 GENERAL DESCRIPTION

The Model 300A Harmonic Wave Analyzer is a selective voltmeter designed to measure the individual components of complex waves. The selectivity can be varied by means of selective amplifiers to measure either closely or widely spaced harmonics. The instrument covers the audio spectrum from 30 to 16,000 cps. It has a wide voltage range so that full scale readings may be obtained from 1 millivolt to 500 volts.

The Model 300A is well adapted to the measurement of the harmonic distortion in audio frequency equipment of all kinds, broadcast receivers, transmitters; to determine the harmonic components in ac machinery and power systems; to the study of induced voltages on telephone lines; and to measurement of hum components in rectifier circuits.

Other uses include the study of noise by integrating portions of the spectrum with the selectivity control adjusted for a wide pass band and the checking of wave filter characteristics with maximum selectivity.

The Model 300A is also useful as a device to measure the amount of cross or intermodulation products generated by the simultaneous transmission of two frequencies by an audio system or to measure demodulation of a modulated wave applied through an audio system.

1-2 SPECIFICATIONS

Complete specifications for the hp Model 300A Harmonic Wave Analyzer will be found on page 3 of the hp No. 300A-2 Service Manual.

SECTION II

OPERATING INSTRUCTIONS

2-1 230 VOLT OPERATION

This instrument is shipped from the factory with the power transformer primaries connected in parallel for operation from 115 volts. If operation from a power line of 230 volts is desired, the power transformer primaries must be connected in series as shown by the "Transformer Detail" on the schematic diagram in Fig. 3 on page 39 of the No. 300A-2 Service Manual.

Some older instruments have a power transformer with a single primary winding for operation from 115 volts only.

The 1.25 ampere slo-blo fuse required for 115 volt operation must be replaced by a 0.6 ampere slo-blo fuse after changing primary connections from parallel to series for operation from 230 volts.

2-2 CONTROLS AND TERMINALS

All controls and terminals are fully described on pages 4 and 5 of the (hp) No. 300A-2 Service Manual.

CAUTION

THIS INSTRUMENT IS ACCURATE AT AMBIENT TEMPERATURES OF APPROXIMATELY 55 TO 95 DEGREES FAHRENHEIT. OTHER AMBIENT TEMPERATURES MAY NECESSITATE REALIGNMENT OF THE SELECTIVE AMPLIFIER SYSTEM.

2-3 OPERATION

The operation of the Model 300A is divided into two parts, the calibration adjustment procedure and the measurement procedure.

2-4 CALIBRATION ADJUSTMENT PROCEDURE

This procedure will be found under the heading of CALIBRATION PROCEDURE starting on page 11 of the (hp) No. 300A-2 Service Manual.

See the important operating precautions given in step 26 of CALIBRATION PROCEDURE in the No. 300A-2 manual.

2-5 MEASUREMENT PROCEDURE

The instrument must be calibrated before attempting a measurement. In the following procedure, the voltage being analyzed has a fundamental frequency of 80 cps and an amplitude of 20 volts. The frequency and amplitude of this hypothetical voltage have been assumed to simplify the instructions. Any voltage between 1 millivolt and 500 volts at any frequency between 30 to 16,000 cps could be similarly measured. A harmonic frequency must not be higher than 16,000 cps if the particular harmonic voltage is to be measured.

- a. Calibrate the 300A as previously described.
- b. Set the METER MULTIPLIER control to 50 (X100) and the SET TO 100 FOR VOLTAGE MEASUREMENT control to 100.
- c. Set the HALF BAND WIDTH control to 30. See step 26B on page 12 of No. 300A-2 Service Manual regarding the degree of selectivity necessary for measuring voltages of various frequencies.
- d. Set the frequency dial to 80 cps and peak the meter indication by adjusting the FINE TUNING control. The METER SENSITIVITY control should be adjusted to give a readable indication on the millivoltmeter. The instrument is now tuned to measure the amplitude of the fundamental frequency (80 cps) with the harmonics excluded.
- e. The actual value of the fundamental voltage is found by multiplying the millivoltmeter indication by the multiplying factor shown by the position of the METER MULTIPLIER control.

Example:

METER SENSITIVITY at 500 (5.0 on meter scale) full scale millivolts.
Meter pointer at 2.0 therefore meter actually indicates 200 millivolts.
200 millivolts x 100 (meter multiplier factor) is equal to 20,000 millivolts
or 20 volts.

- f. Turn the frequency dial to 160 cps (second harmonic of 80 cps) and set the METER SENSITIVITY and METER MULTIPLIER controls to obtain a readable meter indication. Use the FINE TUNING control to peak the meter indication. The meter indication times the meter multiplying factor will give the amplitude of the second harmonic.
- g. Repeat step f. at as many higher harmonics as desired until the harmonic voltages become too small to measure. In some cases, the harmonic frequency will be higher than 16,000 cps which will be outside the range of the 300A.

2-6 MEASUREMENT PRECAUTIONS

The results obtained with the 300A will depend upon how closely the operator follows a few simple but very important operating precautions. These precautions are given in step 26 of PROCEDURE FOR CALIBRATION on page 12 of  No. 300A-2 Service Manual.

In addition, a 20 KC filter should be used between the voltage to be measured and the input terminals of the Model 300A when voltages at frequencies of 5 KC or 10 KC are being measured. This filter will prevent the fourth harmonic of the 5 KC voltage or the second harmonic of the 10 KC voltage from entering the 20 KC selective amplifier and causing erroneous measurements.

2-7 SELECTIVITY

When operating the Model 300A, it should be borne in mind that the instrument is a frequency selective, wide range voltmeter whose selectivity is variable. It is necessary during operation to determine the degree of selectivity desired and to adjust the instrument correctly to obtain that degree of selectivity.

Determination of the proper selectivity to use in a particular measurement should primarily be based on the fact that unwanted voltages must be attenuated by the selectivity of the instrument to less than one third of the voltage under measurement. This attenuation is, in turn, dependent upon the order of separation of unwanted voltages from the desired voltage, and the relative magnitudes of the various voltages involved.

Instrument selectivity is controlled by the HALF BAND WIDTH control which is calibrated from "30" to "145". These calibrations indicate the frequency separation from the center frequency at which the selectivity characteristics of the instrument attenuates by 40 db (99%).

Another way of saying the same thing is that the HALF BAND WIDTH calibrations indicate the minimum frequency separation from a 100% voltage which will permit accurate measurement of a 3% voltage.

It will often be found convenient to use only two degrees of selectivity as obtained by setting the HALF BAND WIDTH control at "145" for minimum

2-7 SELECTIVITY (Cont'd.)

selectivity or at "30" for maximum selectivity. Use minimum selectivity for voltages with a fundamental frequency higher than 100 to 300 cps. Use maximum selectivity for voltages with a fundamental frequency lower than 100 to 300 cps. This system eliminates the necessity of determining whether an intermediate degree of selectivity offers sufficient attenuation for the case at hand.

Occasionally, however, it is desirable to use degrees of selectivity which are intermediate between minimum and maximum. An example follows to illustrate a typical case of selectivity determination.

Refer to Fig. 2 on page 38 of the No. 300A-2 Service Manual which shows the selectivity characteristics of the 300A for the two extremes of the HALF BAND WIDTH control. A convenient graph for converting attenuation in terms of decibels to percentage is given in Fig. 9 on page 45 of the No. 300A-2 Service Manual.

The graphs of Figs. 2 and 9 are used to determine the setting of the HALF BAND WIDTH control as illustrated in the following:

Assume that it is desired to measure the harmonics of an 80 cps fundamental and that harmonics which are 0.5% or higher are of interest.

Unwanted voltages must be attenuated to less than 1/3 of the voltage under measurement and for this particular case it would be 1/3 of 1/2% or 1/6 of 1%. In other words, when measuring the second harmonic, the fundamental must be reduced to 1/6 of 1% of its value by the 300A selectivity characteristics. Referring to Fig. 9, we see that 1/6 of 1% is equivalent to approximately 56 decibels. Therefore, the HALF BAND WIDTH control must be adjusted so that the instrument will attenuate by 56 decibels for a frequency separation of 80 cps.



Refer to Fig. 2 and sketch in a curve similar to the two curves shown. The new curve should pass through the 56 db point at 80 cps off resonance. Note the point where the new curve passes the 40 db line. This point has an abscissa of about 50 cycles off resonance. Therefore, the HALF BAND WIDTH control should be set at "50" to obtain 56 db attenuation at 80 cps off resonance.

The instrument must then be calibrated using a HALF BAND WIDTH setting of "50" instead of "30" in steps 20 through 23 of PROCEDURE FOR CALIBRATION on page 12 of No. 300A-2 Service Manual. See step 26B on the same page for additional information.

SECTION III

CIRCUIT DESCRIPTION

3-1 GENERAL

The circuitry of the  Model 300A Harmonic Wave Analyzer is discussed on pages 8, 9, 10, and 11 of the  No. 300A-2 Service Manual.

SECTION IV
MAINTENANCE

4-1 CABINET REMOVAL

To remove the instrument from the cabinet it is necessary to unscrew the eight large Phillips head screws on the control panel and slide the instrument forward out of the cabinet.

In some older instruments, it may be necessary to remove the wire connecting the bottom chassis to the metal plate in the bottom of the cabinet. This wire will be found on the rear of the instrument.

4-2 TUBE REPLACEMENT

Refer to page 7 of Service Manual No. 300A-2 for complete instructions on tube replacements.

4-3 LOCAL OSCILLATOR AMPLITUDE ADJUSTMENT

This adjustment can be made at any time as directed in step 2 of PRELIMINARY TESTS & ADJUSTMENTS on page 13 of No. 300A-2 Service Manual.

4-4 VOLTAGE REGULATOR ADJUSTMENT

The output of the regulated power supply section in the 300A should be checked from time to time as directed in step 1 of PRELIMINARY TESTS & ADJUSTMENTS on page 13 of No. 300A-2 Service Manual.

4-5 HUM BALANCE ADJUSTMENT

The hum balance control R159 is located on the bottom deck of the instrument next to the heater transformer. The procedure for adjusting this control is given in FINAL TEST step 8 on page 17 of No. 300A-2 Service Manual.

4-6 BALANCED MODULATOR ADJUSTMENT

The procedure for adjusting the balanced modulator to minimize harmonic distortion is given on page 18 of No. 300A-2 Service Manual in step 10 under FINAL TEST.

4-7 SELECTIVE AMPLIFIER ADJUSTMENT

The detailed procedure for adjusting the selective amplifier system in the 300A is given on pages 14 and 15 of the No. 300A-2 Service Manual.

SECTION V
TABLE OF REPLACEABLE PARTS

5-1 GENERAL

A table of replaceable parts which is suitable for use with all 300A instruments is given in the $\text{\textcircled{hp}}$ No. 300A-2 Service Manual. This table begins on page 51 of the manual.

OPERATION AND SERVICE MANUAL
FOR

MODEL 300A
HARMONIC WAVE ANALYZER
300A-2A

This is a combined Operation and Service Manual for all  Model 300A Harmonic Wave Analyzers. This manual contains complete operation and servicing instructions for the 300A and may be used in place of the Instruction and Operating Manual originally supplied with each instrument.

Copyright 1955 by Hewlett-Packard Company

The information contained in this booklet is intended for the operation and maintenance of Hewlett-Packard equipment and is not to be used otherwise or reproduced without the written consent of the Hewlett-Packard Company.

HEWLETT-PACKARD COMPANY
275 PAGE MILL ROAD, PALO ALTO, CALIFORNIA, U.S.A.

300A002

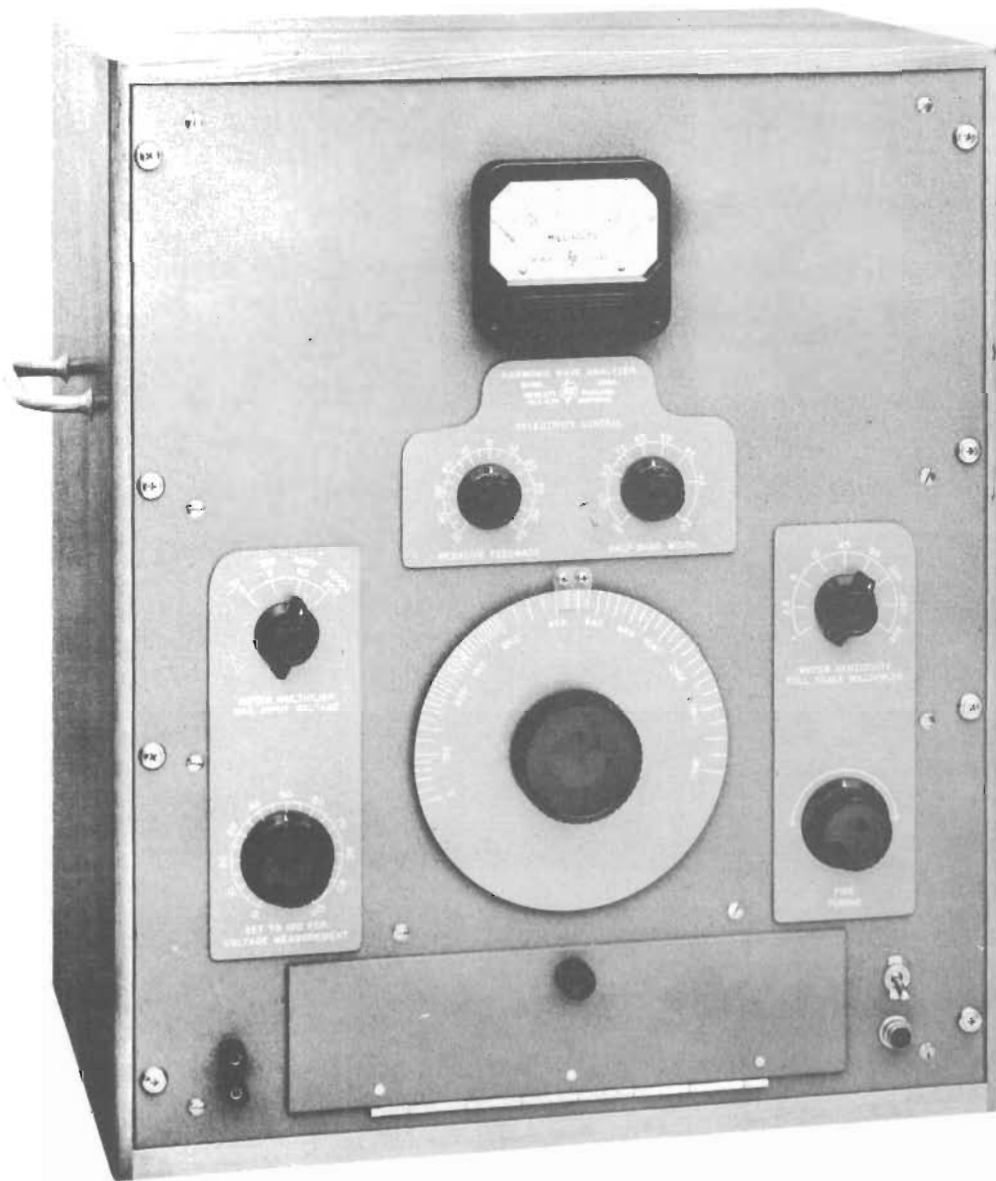

Typical Front View of -hp- Model 300A Harmonic Wave Analyzer

TABLE OF CONTENTS & INDEX

	PAGE
SPECIFICATIONS	3
ACCESSORIES AVAILABLE	3
CONTROLS & TERMINALS	4
TUBE COMPLEMENT & TUBE REPLACEMENTS	7
CIRCUIT DESCRIPTION	
General	8
Input & Phase Inverter Circuits	8
Modulator Circuit & Voltage Amplifier	9
Local Oscillator	9
Power Supply	10
Selective Amplifier System	10
Voltmeter Circuit	11
CALIBRATION PROCEDURE	
General	11
Procedure for Calibration	11
TEST PROCEDURE	
Instruments Required for Test Procedure	13
Preliminary Tests & Adjustments	13
1. Adjustment of B+	13
2. Adjustment of Local Oscillator Injection Voltage	13
3. Centering Tuning Range of "F" Control	14
4. Check Oscillator Stability	14
Selective Amplifier Alignment	14
Heat Run Check	16
Final Test	16
1. Check & Adjust Regulated B+ Voltage	16
2. Check & Adjust Oscillator Injection Voltage	16
3. Oscillator Response to Line Voltage Change	16
4. Final Alignment of Selective Amplifier	16
5. Adjust Millivolts Meter to Zero	16
6. Centering Range of Control "C"	16
7. Check for Carrier Leakage	16
8. Check for Hum (Balance Hum Control R159)	17
9. Check Resonance Curves	17
10. Check Harmonic Distortion (Adjust Control R117)	18
11. Checking Variable Selectivity Control	18
12. Checking Millivolts Meter Tracking	18
13. Checking Instrument Sensitivity	18
14. Frequency Calibration - Check & Adjustment	19
15. Frequency Response Check	19
16. Check Voltage Calibration	20
17. Checking Meter Sensitivity Control	20
18. Checking Meter Multiplier Control	21
19. Correcting Unsteady Millivolts Meter Readings	21
20. Adding "CALIBRATION PROCEDURE" Labels	21
21. Mechanical Inspection	21
22. Instrument Bottom Plate Replacement	21
23. Completion of Final Test	21
CIRCUIT MODIFICATIONS	
General	23
Top Deck Modernizing Procedure	23
Parts Required for Complete Top Deck Modernization	24
Bottom Deck Modification Procedure	25
Modification to Reduce Carrier Leakage	25
Power Supply Modification	26
Other Lower Deck Modifications	27
TROUBLE SHOOTING	
General	29
Trouble Chart	29

TABLE OF CONTENTS & INDEX (Cont'd.)

	PAGE
FIGURES & ILLUSTRATIONS	
Fig. 1. Block Diagram of -hp- Model 300A Analyzer	37
Fig. 2. Characteristics of Selective Amplifier System	38
Fig. 3. Schematic Diagram Serial No. 1330 & Above - Selective Amplifier (Top Deck)	39
Fig. 4. Schematic Diagram Serial No. 1610 & Above - Modulator, Oscillator, Power Supply (Lower Deck).	40
Fig. 5. Typical Schematic Diagram, Serial No. 1329 & Below - Selective Amplifier (Top Deck)	41
Fig. 6. Typical Schematic Diagram, Serial No. 1609 & Below - Modulator, Oscillator, Power Supply (Lower Deck).	42
Fig. 7. Partial Schematic Diagrams Showing Early Circuitry	43
Fig. 8. Chart for Plotting Selectivity Curves	44
Fig. 9. Decibel to Voltage Ratio Conversion Graph	45
Fig. 10. Top View of Typical Bottom Deck	46
Fig. 11. Bottom View of Typical Bottom Deck	47
Fig. 12. Top View of Typical Top Deck - Less Panel	48
Fig. 13. Bottom View of Typical Top Deck - Less Bottom Plate	49
TABLE OF REPLACEABLE PARTS	
General	51
Replaceable Parts Table	51
List of Manufacturers Code Letters for Replaceable Parts Table	50

SPECIFICATIONS

FREQUENCY RANGE -

30 to 16,000 cycles per second.

FREQUENCY CALIBRATION -

Within ±3% or better.

VOLTAGE RANGES -

Covers range between 0.1 millivolt and 500 volts with full scale readings of: 500, 250, 100, 50, 25, 10, 5, 2.5, 1.0, 0.5, 0.25, and 0.1 volts plus full scale millivolt ranges of 50, 25, 10, 5, 2.5, and 1.

OVERALL VOLTAGE ACCURACY -

Voltage readings are accurate to within ±5% of full scale value provided harmonics are spaced so as to be suppressed by the selectivity of the instrument.

RESIDUAL MODULATION PRODUCTS -

Suppressed at least 65 db.

FUM VOLTAGE -

At least 75 db below 0.5, 5, 50, or 500 volts, depending upon input range selected.

SELECTIVITY -

Variable selectivity permits adjusting frequencies 30 to 145 cps away from the resonant frequency so they are 40 db below the resonant frequency while maintaining constant gain.

<u>APPROX. db BELOW MAXIMUM RESPONSE</u>	<u>DEVIATION FROM CENTER FREQUENCY WITH MAXIMUM SELECTIVITY</u>	<u>DEVIATION FROM CENTER FREQUENCY WITH MINIMUM SELECTIVITY</u>
3 db	3.5 cps	14 cps
10 db	8.0 cps	37 cps
40 db	30.0 cps	145 cps
60 db	53.0 cps	280 cps

INPUT IMPEDANCE -

Input impedance is 200,000 ohms.

POWER -

115 or 230 volts, ±10%
50 to 60 cps
105 watts

DIMENSIONS -

Cabinet Model: 23" wide, 24" high, 14" deep.
Rack Model: 19" wide, 22-3/4" high, 12" deep.

WEIGHT -

80 pounds for either model. Shipping weight of cabinet model is 150 pounds.

ACCESSORIES AVAILABLE -

The following accessories are available for use with the 300A. For additional information see our local sales representative or contact the factory directly.

<u>DESCRIPTION</u>	<u>-hp- MODEL NO.</u>
Cable Assembly; dual banana plugs with 3/4" spacing on each end of a 4 foot length of RG-58/U cable	AC-16A
Cable Assembly; dual banana plug with 3/4" spacing on one end of a 4 foot length of RG-58/U cable and a UG-88/U type BNC male connector on the other end.	AC-16B
Transformer, Bridging; for connecting 300A input to a balanced line	AC-60B

300A002 11/30/55

CONTROLS & TERMINALS

INPUT TERMINALS -

The two binding posts located in the lower left corner of the control panel are the instrument input terminals. The lower binding post is connected to the chassis.

METER MULTIPLIER MAX. INPUT VOLTAGE -

This four position rotary switch determines the maximum voltages that may be applied to the instrument without circuit overloading. This control, in conjunction with the METER SENSITIVITY control, indicates the multiplication factor for the MILLIVOLTS meter reading. The figures nearest the knob are the maximum voltages while the outer figures are the multiplication factors.

SET TO 100 FOR VOLTAGE MEASUREMENT -

This potentiometer provides a control for reducing the input voltage as required for relative voltage measurements. This control is calibrated from 0 to 100 in arbitrary units.

OPERATING PRECAUTION

VOLTAGE MEASUREMENTS ARE CORRECT ONLY WHEN THE SET TO 100 FOR VOLTAGE MEASUREMENT CONTROL IS SET TO "100" AND THE HALF BANDWIDTH CONTROL IS SET TO THE SAME POSITIONS SELECTED FOR CALIBRATION.

NEGATIVE FEEDBACK -

This control is used to maintain constant amplifier gain with different settings of the HALF BAND WIDTH control and is calibrated 50-0-50 in arbitrary units. Instructions for setting this control are given in the PROCEDURE FOR CALIBRATION.

Some older instruments in the field are not provided with this control. In these instruments, it will be necessary to recalibrate each time the setting of the HALF BAND WIDTH control is changed.

HALF BAND WIDTH -

Instrument selectivity is determined by the setting of this control. The calibrations of 30 to 145 on the scale around this control knob indicate the number of cycles off resonance the input signal must be in order to be attenuated 40 db. Instructions for setting this control are given in the PROCEDURE FOR CALIBRATION.

FREQUENCY DIAL -

The frequency dial and internal tuning capacitor are driven by the vernier knob in the center of the dial. The dial scale is calibrated from 0 to 16 KC in terms of the input signal frequency.

METER SENSITIVITY -

This tapped voltage divider controls the amplitude of the voltage supplied to the selective amplifier and the position of the knob indicates the full scale value, in millivolts, of the meter scale in use.

MILLIVOLTS METER-

This meter indicates the voltage measured by the instrument. The meter has three scale calibrations. The scale in use and the scale multiplication factor are indicated by the position of the METER SENSITIVITY FULL SCALE MILLIVOLTS and the METER MULTIPLIER MAX. INPUT VOLTAGE controls.

FINE TUNING -

This variable capacitor provides an incremental adjustment for the frequency dial. The instrument is calibrated with this control rotated so that the mark on the knob skirt is straight up over the center of the control.

ON - OFF SWITCH -

This toggle switch controls the power supplied to the instrument from the power line. When the instrument is turned on, the indicator lamp below the toggle switch will light.

300A002 11/30/55

CONTROLS & TERMINALS (Cont'd.)

POWER CABLE -

There are three wires in the power cable. Two of these wires (usually black and white) carry power to the instrument. The remaining wire (usually green) is connected internally to the instrument chassis and protrudes from the power cable at the plug end for grounding the instrument.

FUSE -

The fuseholder, located on the back of the lower chassis or deck, contains a 1.25 ampere slo-blo cartridge fuse. The fuse may be replaced by unscrewing the fuseholder cap and inserting a new fuse. Fast blow 2 ampere fuses were originally used in these instruments. The 1.25 ampere slo-blo fuses are recommended for replacement since they offer increased instrument protection. Those instruments that have been changed for 230 volt operation require a 0.6 ampere slo-blo fuse for replacement.

SUB-PANEL CONTROLS -

Controls C, F, G, R, S, and V are located behind the door at the bottom of the control panel. These are non-operating controls used for instrument calibration.

CONTROL C - This control is used to balance the capacity across the two modulation transformer primaries.

CONTROL F - This control provides an adjustment for setting the local oscillator frequency to 20 KC when the frequency dial is set to zero.

CONTROL G - Overall instrument gain is determined by the setting of this control.

CONTROL R - This control provides a resistance balance between the two modulation transformer primaries.

CONTROL S - This lever switch selects the input signal for phase inverter stage V101. When this switch is to the right, the internal calibrating voltage is connected to V101. With this switch in the remaining position, the input voltage is connected to the grid of V101.

CONTROL V - This control permits setting the internal calibrating voltage to 5 volts. A ten to one voltage divider following this control delivers 0.5 volts for instrument calibration.

VOLTS METER - This meter measures the internal calibrating voltage as adjusted by control V.

TUBE COMPLEMENT & TUBE REPLACEMENTS

GENERAL -

Any tubes with RETMA standard characteristics may be used for replacement purposes. However, as noted in the instructions that follow, use of a selected tube will improve instrument performance in some cases.

The 300A is a high gain instrument. Tubes that are microphonic or have relatively high heater to cathode leakage are not desirable.

The tube type used for some of the stages in the 300A have varied with time. In some cases use of a later tube type is recommended but not necessary. If in doubt, replace tubes with the same type found in the instrument.

The number of adjustments required will depend upon the tube replaced. The specific tests and/or adjustments are given in the chart that follows. This chart also shows where the procedures for these tests and adjustments can be found in the TEST PROCEDURE section of this manual.

CIRCUIT REFERENCE	ORIGINAL TUBE TYPE	RECOMMENDED REPLACEMENT	TESTS, ADJUSTMENTS, AND/OR SPECIAL NOTES
V1 thru V8	6SJ7	6SJ7	FINAL TEST procedure steps 8 and 9. Low microphonic tubes are best.
V9	6F8 or 6SN7	6F8 or 6SN7	Replace with same type as in instrument. FINAL TEST step 3.
V10	6H6	Aged 6H6	Select tube giving minimum change in zero setting between instrument on and off with no input signal. Complete FINAL TEST step 3.
F 101	2 amp fast blow or 1.25 amp slo-blo for 115 V. operation.	1.25 amp slo-blo	Slo-blo fuse gives better instrument protection. Use different fuse for 230 volt operation as noted under <u>FUSE</u> in the <u>CONTROLS & TERMINALS</u> section.
R140 lamp	3 watts, 115 volts or 10 watts, 230 volts	10 watts 230 volts	FINAL TEST step 2. See step 1 of <u>OTHER LOWER DECK MODIFICATIONS</u> under <u>BOTTOM DECK MODIFICATION PROCEDURE</u> in <u>CIRCUIT MODIFICATIONS</u> section.
V 101	6SJ7	6SJ7	FINAL TEST procedure steps 3, 6, 8, & 10. Use a tube with low microphonics and check for a "hump" in the resonance curves as directed in FINAL TEST procedure step 9.
V 102 & V 103	6SJ7	6SJ7 selected as a matched pair.	
V 104	6SJ7	6SJ7	FINAL TEST step 3. Check for low microphonics, hum, and 60 cps "hump". FINAL TEST step 9a.
V 105	6J7	6J7	Changing either tube will not cause appreciable change in frequency or oscillator injection voltage. Check by repeating steps 2, 3, 8, 10, and 14 of FINAL TEST. Oscillator output should be stable. Tubes should be non-microphonic.
V 106	6F6	6F6	

TUBE COMPLEMENT & TUBE REPLACEMENTS (Cont'd.)

GENERAL (Cont'd.)

CIRCUIT REFERENCE	ORIGINAL TUBE TYPE	RECOMMENDED REPLACEMENT	TESTS, ADJUSTMENTS, AND/OR SPECIAL NOTES
V 107	NE16 Neon Tube or OA2	NE16 or OA2	The two tube types given are not interchangeable. Replace with same type as found in instrument. Set B+ according to instructions in step 1 of FINAL TEST.
V 108	6SQ7 or 6SF5	6SQ7 or 6SF5	
V 109	6L6G, 6L6GA, 6L6GB, or 6Y6	6L6GB	FINAL TEST step 1. All of these tube types have the same pin connections. Resistor R164 must be in screen circuit if 6Y6 is used.
V 110	5Y3GT, 5Z4, 5U4G, 5U4CA, or 5U4GB	5U4GB	FINAL TEST step 1. Best power supply regulation will be obtained in some cases by replacing with the same tube type as in instrument. All of these rectifiers are interchangeable in the 300A with no change in pin connections. Voltage rating of output electrolytic capacitors must not be exceeded.

CIRCUIT DESCRIPTION

GENERAL -

The -hp- Model 300A Harmonic Wave Analyzer is a frequency selective heterodyne type voltmeter designed to measure individual components of complex waveforms. Full scale meter readings can be obtained from input voltages varying between 1 millivolt and 500 volts. Instrument selectivity can be varied to measure either closely or widely spaced harmonics over the audio spectrum from 30 to 16,000 cps.

Basically, the circuit consists of a phase inverter, a local oscillator, a balanced mixer, a four section selective amplifier, and a vacuum tube voltmeter. In addition to these basic circuits, the Model 300A includes input and range multipliers as well as an internal calibrating system for use in standardizing overall instrument gain. The block diagram given in Fig. 1 shows the function of the individual circuits and controls.

The instrument is divided into two chassis with a common front panel. The upper chassis contains the selective amplifier and vacuum tube voltmeter sections. The remaining circuits are located in the lower chassis. The schematic diagram is similarly divided.

INPUT & PHASE INVERTER CIRCUITS -

The input terminals in the lower left corner of the instrument panel are connected to METER MULTIPLIER switch S101 which provides ranges of X1, X10, X100, and X1000. In addition, each position of this switch is calibrated in the maximum input voltage that may be applied without overloading the circuits of the instrument. Erroneous readings will result from circuit clipping when the input signal is higher than these panel markings.

The METER MULTIPLIER switch is followed by the SET TO 100 control which must be set to the 100 position in order to obtain a correct voltmeter reading when measuring the actual value of the input voltage.

Switch S102 ("S") permits connecting the input of the 6SJ7 phase inverter tube V101 to the input signal or to the internal calibration circuit.

CIRCUIT DESCRIPTION (Cont'd.)

INPUT & PHASE INVERTER CIRCUITS - (Cont'd.)

The internal calibration circuit obtains 6.3 volts from a heater winding on the power transformer. Control "V" permits setting the voltage to obtain a reading of 5 volts on the internal calibrating voltmeter. The values of R106 and R107 are chosen to obtain a 10 to 1 voltage division ratio and are factory adjusted to obtain a 0.5 volt calibration voltage when the calibration voltmeter reads 5 volts.

Phase inverter V101 is a triode connected type 6SJ7 pentode tube. The load resistor (other than cathode resistor R111) for this tube is effectively 44,000 ohms and consists of R112 and R114 in series. With R112 in the cathode circuit and R114 in the plate-circuit, the signal voltage delivered to the modulator tubes through coupling capacitors C103 and C105 are equal in amplitude and 180 degrees out of phase with each other.

MODULATOR CIRCUIT & VOLTAGE AMPLIFIER -

The modulator circuit consists of two type 6SJ7 tubes (V102 and V103) in a balanced push-pull circuit. Potentiometer R117 provides an adjustment for balancing the modulator input circuits. This control is set during FINAL TEST and is not an operating control. Variable capacitor C107 (control "C") and potentiometer R123 (control "R") provide balancing adjustments for the modulator output circuits.

The local oscillator voltage is injected into the cathode circuit of V102 and V103 at the top of their common cathode resistor (R120). The local oscillator operates at a frequency 20 KC higher than the input signal.

The push-pull modulator tubes will have the input and local oscillator frequencies present in their output as well as the sum and difference frequencies.

Transformer T101 is designed for operation at 20 KC and readily accepts the 20 KC lower side-band and passes it on to the selective amplifier. These amplifiers are peaked to amplify a 20 KC signal. Any portion of the original signal arriving at the input to this amplifier system will be rejected by the amplifier.

The local oscillator signal is applied to V102 and V103 from a common source and hence appears in both plate circuits in the same phase and will be cancelled out across the balanced primary of T101. Balance is obtained by adjusting controls "C" and "R".

This balance becomes increasingly important at the lower frequency limit of the 300A. When the frequency dial is set to zero the local oscillator frequency is 20 KC. If the modulator tubes are not balanced, the 20 KC signal from the local oscillator will feed through the selective amplifier and give an erroneous reading on the 300A.

Potentiometer R125 (control "G") across the secondary of T101 provides an adjustment for standardizing overall amplifier gain.

METER SENSITIVITY switch S103 permits changing the amplifier input by any one of nine fixed ratios. This effectively acts as a control of meter sensitivity and when used in conjunction with the METER MULTIPLIER, switch S101, provides 18 full scale voltmeter ranges from 500 volts to 1 millivolt.

Tube V104 is a triode connected type 6SJ7 tube functioning as a voltage amplifier. The output from this tube is connected to a shielded cable terminated by a two prong plug. The shielded cable carries the 20 KC signal from the lower chassis to the upper chassis. A two prong socket is mounted in the upper chassis.

LOCAL OSCILLATOR -

The local oscillator is the resistance-capacity tuned circuit commonly found in -hp- instruments. Tubes V105 and V106 function basically as a two stage voltage amplifier with the output of V106 coupled to the grid and cathode circuits of V105. The grid circuit coupling produces regenerative feedback to maintain oscillation while the cathode circuit coupling produces degenerative feedback to stabilize the oscillator output.

The oscillator tunes over a relatively narrow range from 20 KC to 36 KC and has constant output over this range. Consequently, the amplitude of the 20 KC signal fed to the selective amplifier system is dependent upon the amplitude of the input signal.

CIRCUIT DESCRIPTION (Cont'd.)

LOCAL OSCILLATOR - (Cont'd.)

The frequency dial is calibrated to indicate the frequency of the input signal and not the local oscillator frequency which is 20 KC higher than the dial indication.

The 5 to 65 μ f trimmer (C114 control "F") provides an adjustment for setting the local oscillator frequency. With the frequency dial set to "0", control "F" is adjusted for a maximum indication on the 300A voltmeter. This adjustment tunes the local oscillator to the 20 KC peak of the selective amplifiers. An accurately known external source connected to the 300A input terminals can also be used for adjusting the local oscillator. The 300A frequency dial is set to the same frequency as the external source and control "F" is adjusted for a maximum indication on the 300A meter.

Local oscillator output is obtained from V106 cathode circuit and injected into the cathode circuit of V102 and V103. Injection voltage is set with the frequency control dial at "0" by adjusting potentiometer R143 which controls negative feedback from V106 to the cathode of V105. The 20 KC injection voltage measured at the top of cathode resistor R120 for V102 and V103 should be 2 volts.

POWER SUPPLY -

High voltage is obtained from a 5U4G/AB full wave rectifier followed by a two section capacity input L-C filter. This filtered dc output furnishes B+ for all selective amplifier circuits as well as the voltmeter circuit in the upper chassis. The filtered dc is also passed through a voltage regulator, the output of which supplies V101 through V106 in the lower chassis.

An OA2 voltage regulator tube V107 supplies the necessary reference voltage for the 6SQ7 regulator control tube V108 which in turn controls the 6L6GB series regulator tube V109. Tube types for V107, V108, and V109 may vary between instruments.

Potentiometer R152 is an adjustment for setting the output of the regulated portion of the power supply to +240 volts.

SELECTIVE AMPLIFIER SYSTEM -

The selective amplifier system consists of a total of eight type 6SJ7 tubes. These tubes are paired to give effectively four amplification stages. All four stages function in the same manner. Consequently, only the first stage involving V1 and V2 will be discussed.

The signal from voltage amplifier V104 in the lower chassis is fed through a shielded cable to the grid circuit of V1 in the upper chassis. Coil L1 in the grid circuit is tuned to 20 KC by C1 and C2. The resistor of 830,000 ohms in the grid circuit prevents the preceding stage from loading the resonant circuit.

The amplified 20 KC signal is developed across one section of the HALF BAND WIDTH control. With this control rotated full counterclockwise, the control arm is at ground potential and there is no feedback from V2 to V1 through R5, R8, R9, or R10 resistors. Amplifier gain is determined by the fixed degenerative coupling through R11 and C37 between V2 output and V1 cathode circuit. Amplifier selectivity is at minimum and is primarily determined by the resonant circuit in the grid circuit of V1. Resistor R74 will control the "Q" of the tuned circuit and hence also control amplifier selectivity under these conditions.

As the HALF BAND WIDTH control is rotated clockwise, more and more of the plate signal from V2 is fed back to the grid circuit of V1. This signal is in phase with the input signal and the circuit becomes regenerative. The selectivity of the two stages becomes progressively sharper as regeneration increases.

The positive feedback would also cause an increase in gain if it were not for negative feedback through R5, R8, and R10 to the cathode of V1 from the same point as the positive feedback. By design, circuit constants have been chosen to permit adjustment of the amount of negative feedback. By properly setting the NEGATIVE FEEDBACK control, as described in the Operating Instructions, it is possible to vary the selectivity of stages V1 and V2 while maintaining constant amplifier gain.

The remaining three sections of the selective amplifier operate in an identical manner. Tubes V3 and V4 comprise the second section, tubes V5 and V6 the third section, and tubes V7 and V8 the fourth section.

CIRCUIT DESCRIPTION (Cont'd.)

SELECTIVE AMPLIFIER SYSTEM - (Cont'd.)

The HALF BAND WIDTH control consists of four ganged potentiometers which control feedback in all four amplifier sections simultaneously. This control is calibrated 145 to 30. The divisions on this scale indicate the number of cycles away from the resonant frequency at which the amplifier response will be down 40 db (99%).

The NEGATIVE FEEDBACK control also consists of four ganged potentiometers which provide simultaneous negative feedback control in all four amplifier sections. This control is calibrated 50-0-50 in arbitrary units.

The 20 KC toroid coils used in the selective amplifier sections are manufactured using the most up to date techniques known with the most recent engineering data in order to insure instrument accuracy over an ambient temperature range of approximately 55 to 95 degrees Fahrenheit. Ambient temperatures outside of this range may necessitate realignment of the selective amplifier.

VOLTMETER CIRCUIT -

The vacuum tube voltmeter voltage amplifier, V9, consists of two triode sections of a type 6SN7GT tube connected in a conventional resistance coupled amplifier circuit. The output of this amplifier is fed to a 6H6 tube in a full wave rectifier circuit. The ground return for the rectifier circuit is made through the cathode resistor for the first triode section. This introduces inverse or negative feedback which stabilizes the vacuum tube voltmeter circuit.

The indicating meter has a basic 0-1 milliampere movement with the scale calibrated in three ranges of 0-1, 0-2.5, and 0-5 millivolts.

CALIBRATION PROCEDURE

GENERAL -

The instrument should be given at least 30 minutes for warm up before starting the calibration procedure. This warm up will allow the circuits to reach a stable operating condition. It is also advisable to check the calibration after the instrument has been operating for more than one hour.

PROCEDURE FOR CALIBRATION -

1. Set the main tuning dial to "0".
2. Set the FINE TUNING so that the line is vertical.
3. Set METER SENSITIVITY to "500".
4. Set HALF BAND WIDTH to "30".
5. Set NEGATIVE FEEDBACK to "0".
6. Set METER MULTIPLIER to "X1000".
7. Set input gain control potentiometer (SET TO 100 FOR VOLTAGE MEASUREMENT) full counterclockwise to "0". This control and the METER MULTIPLIER have no effect on the calibration procedure except to isolate the input terminals from the balance of the circuits.
8. Set switch "S" to the left (position vertical to panel).
9. Set control "G" to the center of its range.
10. Adjust control "F" for a maximum MILLIVOLTS meter indication. If MILLIVOLTS meter reads off scale, rotate control "G" to bring pointer on scale.
11. Adjust controls "C" and "R" for a minimum MILLIVOLTS meter reading. Rotate control "G" to increase meter readings and also switch METER SENSITIVITY to lower scales in order to increase meter readings.
12. Set HALF BAND WIDTH to "145".

CALIBRATION PROCEDURE (Cont'd.)

PROCEDURE FOR CALIBRATION - (Cont'd.)

13. Return METER SENSITIVITY to "500".
14. Set switch "S" to the right position.
15. Adjust control "V" for a VOLTS meter reading of 5 volts.
16. Set main tuning dial to power line frequency and adjust for a maximum MILLIVOLTS meter indication. Adjust control "G" as required to keep the MILLIVOLTS meter on scale.
17. Adjust control "G" for exactly 500 millivolts (full scale on MILLIVOLTS meter).
18. Flip switch "S" to the left, METER SENSITIVITY switch to 25, and adjust main tuning dial at 0 for a maximum indication on the MILLIVOLTS meter. If MILLIVOLTS meter reading is off scale, adjust "C" and "R" for a minimum meter reading.
19. Repeat steps 13 through 17.
20. Set HALF BAND WIDTH to "30" and adjust FINE TUNING for a maximum MILLIVOLTS meter reading.
21. Adjust NEGATIVE FEEDBACK control for a full scale MILLIVOLTS meter reading. Rotate control clockwise to increase reading or counterclockwise to decrease reading.
22. Set HALF BAND WIDTH to "145" and adjust FINE TUNING for maximum reading on MILLIVOLTS meter. If reading is not full scale, repeat steps 13 through 17.
23. Repeat steps 20 through 22 until a full scale MILLIVOLTS meter reading is obtained.
24. Flip switch "S" to the left and close the bottom door.
25. Before making voltage measurements, set front panel operating controls as follows: SET TO 100 FOR VOLTAGE MEASUREMENT full clockwise, METER MULTIPLIER to proper range for the voltage being measured, and HALF BAND WIDTH at "145" or "30". Main tuning dial must be tuned to frequency of voltage being measured and the FINE TUNING adjusted for a maximum MILLIVOLTS meter indication.
26. The following precautions must be observed when operating the -hp- Model 300A Harmonic Wave Analyzer:
 - A. For maximum accuracy, recheck calibration from time to time while operating instrument.
 - B. For convenience, set the HALF BAND WIDTH control to "30" when measuring voltages below 300 cps and to "145" for voltages above 300 cps. Any desired intermediate points may be selected and used for a particular application provided these points are used in steps 20 through 23 of PROCEDURE FOR CALIBRATION.
 - C. To make voltage measurements, the input gain control (SET TO 100 FOR VOLTAGE MEASUREMENT) must be full clockwise to "100". The HALF BAND WIDTH control should be set to the point or points used when calibrating. See B above. The instrument can be calibrated and used with the HALF BAND WIDTH control set to provide any desired degree of selectivity between "30" and "145".
 - D. The main tuning dial must be tuned to the signal voltage frequency and the FINE TUNING control adjusted for a maximum MILLIVOLTS meter reading.
 - E. The Model 300A can be used to measure hum in the presence of other signals if the following precautions are observed:
 1. The modulator must be balanced to 10 millivolts or less in step 18 of the CALIBRATION PROCEDURE.
 2. The HALF BAND WIDTH control must be set to "30".
 These precautions are necessary, since this measurement is ordinarily made on the extremely sensitive ranges of the instrument with the local oscillator tuned to 20,060 cps. If the modulator is not balanced very closely, the signal from the local oscillator may feed directly into the selective amplifier. The HALF BAND WIDTH must be set for maximum selectivity to provide additional reduction of the signal from the local oscillator.

CALIBRATION PROCEDURE (Cont'd.)

PROCEDURE FOR CALIBRATION - (Cont'd.)

- F. A 20 KC external signal source operating near the 300A may radiate a signal directly into the selective amplifier of the 300A and produce an erroneous MILLIVOLTS meter reading or a beat.

THIS INSTRUMENT IS ACCURATE WITHIN THE APPROXIMATE AMBIENT TEMPERATURE RANGE OF 55 TO 95 DEGREES FAHRENHEIT. OTHER AMBIENT TEMPERATURES MAY REQUIRE REALIGNMENT OF THE SELECTIVE AMPLIFIER.

TEST PROCEDURE

INSTRUMENTS REQUIRED FOR TEST PROCEDURE -

1. A constant frequency and voltage sine wave source delivering 20 KC with not more than 1% distortion. The -hp- Model 200CD Wide Range Oscillator is recommended. A signal generator with an output attenuator such as -hp- Models 205A, 205AG, 205AH, or 650A can also be used.
2. A frequency measuring device such as an -hp- Model 521, 522, 523, or 524 Electronic Counter is recommended. An -hp- Model 100C or 100D Secondary Frequency Standard used in conjunction with an oscilloscope will also serve the same purpose.
3. A pure sine wave source covering the approximate range from 100 to 6,300 cps with extremely low distortion is needed. The -hp- Model 206A Audio Signal Generator followed by a pure wave filter is recommended.
4. A dc voltmeter such as -hp- Model 410B.
5. A constantly variable transformer for line voltage control.
6. An ac voltmeter such as -hp- Model 330, 400AB, or 400D.
7. An oscilloscope with response up to 36 KC.

IMPORTANT

TEST PROCEDURES MUST BE PERFORMED IN THE SEQUENCE GIVEN.

PRELIMINARY TESTS & ADJUSTMENTS -

The instrument should be turned on at least an hour before making these adjustments. Set the line voltage to 115 volts for all tests unless otherwise instructed.

Unless otherwise designated, refer to Figs. 3 and 4 for circuit references.

1. Set the regulated dc voltage at cathode pin 8 of V109 to 240 volts by adjusting control potentiometer R152. This control will not be found in some older instruments and it will be necessary to pad resistor R50 or R51 shown in Fig. 7C to adjust for 240 volts.

The output of the regulated supply should stay within the limits of 238 and 242 volts when the line voltage is varied between 102 and 128 volts.

2. Set main tuning dial to zero and engraved line on FINE TUNING knob in a vertical position. Measure local oscillator injection voltage at cathode pin 5 of V102 or V103. The 20 KC voltage measured should be 2 volts. Adjust potentiometer R143 until a 2 volt reading is obtained on the voltmeter. If necessary, select a cathode lamp (R140) to bring the oscillator level within the adjustment range of R143. Older instruments have a fixed resistor in place of this control and adjustment is made by padding the value of the fixed resistor.

TEST PROCEDURE (Cont'd.)

PRELIMINARY TESTS & ADJUSTMENTS - (Cont'd.)

3. Set main tuning dial and FINE TUNING controls to the same position used in step 2. Connect frequency measuring equipment and ac voltmeter at cathode pin 5 of V102 or V103. Tune local oscillator to 20 KC by means of sub-panel "F" control. If the oscillator cannot be tuned to 20 KC with the "F" control or if this control does not tune at approximate mechanical center with plates half meshed, adjust variable capacitor C123, or if necessary change values of fixed capacitors C112 and C113. Some early instruments do not have variable capacitor C123 which is mounted on the underside of the lower deck.
4. Check oscillator for stability. Watch pattern on oscilloscope for any sudden changes in frequency or amplitude. Change oscillator tubes (V105 and V106) to correct trouble if it occurs.

SELECTIVE AMPLIFIER ALIGNMENT -

The selective amplifier consists of four stages with two tubes in each stage. All four stages are aligned in the same general manner.

The alignment procedure for instruments with Serial No. 1330 and above or older instruments which have been modernized varies slightly from the procedure for the older instruments which have Serial No. 1329 and below and have not been modernized. These alignment differences are given in the alignment procedure. The type of circuit that a particular instrument has should be determined before starting alignment of the selective amplifier. The MODERNIZING OLDER INSTRUMENTS section of this manual will aid in this circuit identification.

Input and output voltages, when mentioned in the following procedure, are measured between the indicated point in the circuit and the chassis. All circuit references refer to Fig. 3 unless otherwise noted. The amplifier stage or section being aligned can be determined by the prefix number 1, 2, 3, or 4 in the steps of the following alignment procedure.

The selective amplifier stages normally operate with signal levels of very low amplitude. All four stages are basically the same and are each capable of delivering an output signal of 4 volts. Hence, for convenience in testing, the input test signal is adjusted so that the stage output voltage does not exceed 4 volts.

- 1A. Unplug the two prong connector from the top deck and remove the third amplifier tube V3. Remove bottom plate on top deck.
- 1B. Feed a signal of exactly 20 KC (± 5 cps) from an external source into the upper deck two prong connector. The 20 KC source must meet specifications given at the beginning of this TEST PROCEDURE section. Once set, oscillator frequency must be monitored and not allowed to vary more than 1 cps. See above for instructions on setting input signal level.
- 1C. Connect an ac vacuum tube voltmeter to the junction of C7 (0.05 μ f) and R11 (68,000 ohms) in the plate circuit of V2. Adjust external signal source as required to maintain a voltmeter reading no higher than 4 volts.
- 1D. Set the NEGATIVE FEEDBACK control at "-10". This control remains in this position for the balance of the alignment procedure.
- 1E. With the HALF BAND WIDTH control set at "30" adjust trimmer C1 across toroid coil L1 for a maximum indication on the external vacuum tube voltmeter. The trimmer capacitor across the toroid coil must not be tuned with the plates full open or full closed. To do so, will cause a false resonance peak and when the feedback control is adjusted later for normal operation, oscillation will occur. Change the value of fixed capacitor C2 in parallel with the trimmer to center the trimmer when tuned for a peak. Use silver mica or ceramic capacitors with low or zero temperature coefficients.
- 1F. Set the HALF BAND WIDTH control at "145" and adjust for a stage gain of 19 db, $\pm 1/2$ db by padding the lower cathode resistor, R2, for the first tube in the stage. Set older instruments (unmodified Serial No. 1329 and below) for a gain of 19 to 19-1/2 db.

The schematic in Fig. 3 shows this resistor and the corresponding resistor in the following stages as having a nominal value of 900 ohms. The factory adjusted values of these resistors will range from approximately 600 ohms up to 900 ohms.
- 1G. Note the external voltmeter reading and then turn the HALF BAND WIDTH control to "30". Adjust potentiometer R8, in the feedback circuit, to obtain the same external voltmeter reading.
- 1H. Check trimmer setting and stage gain by repeating steps 1E and 1F. If a change is made, repeat step 1G. Replace tube V3.

TEST PROCEDURE (Cont'd.)

SELECTIVE AMPLIFIER ALIGNMENT - (Cont'd.)

- 2A. Remove amplifier tubes V2 and V5. Disconnect voltmeter and connect output from external 20 KC source to this same point (junction of C7 and R11) in plate circuit of V2. Reconnect voltmeter to junction of C16 (0.05 μ f) and R29 (68,000 ohms) in V4 plate circuit.
- 2B. Repeat step 1E except adjust trimmer C9 across toroid coil L2. Change the value of fixed capacitor C10 if necessary to center C9 tuning range.
- 2C. Repeat step 1F except adjust the value of cathode resistor R20. Set older instruments (unmodified Serial No. 1329 and below) for a gain of 17-1/2 to 18 db instead of 19 db, \pm 1/2 db.
- 2D. Repeat step 1G except adjust potentiometer R27.
- 2E. Check trimmer setting and stage gain by repeating steps 2B and 2C. If a change is made, repeat step 2D. Replace tubes V2 and V5.
- 3A. Remove amplifier tubes V4 and V7. Disconnect voltmeter and connect output from external 20 KC source to this same point (junction of C16 and R29) in the plate circuit of V4. Reconnect voltmeter to junction of C24 (0.05 μ f) and R45 (68,000 ohms) in V6 plate circuit.
- 3B. Repeat step 1E except adjust trimmer C17 across toroid coil L3. Change the value of fixed capacitor C18 if necessary to center C17 tuning range.
- 3C. Repeat step 1F except adjust the value of cathode resistor R36. Set older instruments (unmodified Serial No. 1329 and below) for a gain of 17-1/2 to 18 db instead of 19 db, \pm 1/2 db.
- 3D. Repeat step 1G except adjust potentiometer R43.
- 3E. Check trimmer setting and stage gain by repeating steps 3B and 3C. If a change is made, repeat step 3D. Replace tubes V4 and V7.
- 4A. Remove amplifier tube V6. Disconnect voltmeter and connect output from external 20 KC source to this same point (junction of C24 and R45) in the plate circuit of V6. Reconnect voltmeter to junction of C32 (0.05 μ f) and R60 (68,000 ohms) in V8 plate circuit.
- 4B. Repeat step 1E except adjust trimmer C25 across toroid coil L4. Change the value of fixed capacitor C26 if necessary to center C17 tuning range.
- 4C. Repeat step 1F except adjust the value of cathode resistor R52. Set older instruments (unmodified Serial No. 1329 and below) for a gain of 19 to 19-1/2 db instead of 19 db, \pm 1/2 db.
- 4D. Repeat step 1G except adjust potentiometer R58.
- 4E. Check trimmer setting and stage gain by repeating steps 4B and 4C. If a change is made, repeat step 4D. Replace tube V6.
5. Replace bottom plate on top deck and reconnect plugs for two cables connecting top and lower decks. Turn instrument upright.
6. Balance the modulator as previously explained under CALIBRATION PROCEDURE. Adjust the "V" control for a reading of 5 volts on the VOLTS calibration meter. Flip switch "S" to the right.
7. Set HALF BAND WIDTH control to "145", tune in 60 cps and set to a reference point on the MILLIVOLTS meter with the "G" control.
8. Turn HALF BAND WIDTH control to "30" and retune for a maximum reading with the FINE TUNING control.
9. Adjust the NEGATIVE FEEDBACK control to obtain the same reference reading on the MILLI-VOLTS meter. If the NEGATIVE FEEDBACK control is between "15" and "35", the selective amplifier is correctly aligned. Repeat alignment procedure until this test can be passed.
10. Place instrument in its cabinet and allow to operate for several hours before proceeding with the HEAT RUN CHECK that follows.

If new coils have been installed, instrument should be operated continually for at least 24 hours. Up to 3 or 4 days heat run is recommended.

TEST PROCEDURE (Cont'd.)

HEAT RUN CHECK -

1. Allow instrument to operate for several hours. Check the position of the NEGATIVE FEEDBACK control as directed in steps 6, 7, 8, and 9 of the SELECTIVE AMPLIFIER ALIGNMENT procedure and record the control setting.
2. Turn instrument off and let it cool over night. Repeat last step when instrument has been on for a few minutes and again record the NEGATIVE FEEDBACK control setting.
3. Repeat steps 1 and 2 until the instrument is stabilized as indicated by the NEGATIVE FEEDBACK control not requiring excessive adjustment between "hot" and "cold" operating temperatures.

The adjustment required may drift outside the limits of this control. In this case, the amplifier should again be aligned and the unit put on heat run. This realignment may be required a third time.

If the instrument will not stabilize, it may be necessary to replace one or more of the toroid coils. The defective coil can, in most cases, be located during realignment of the selective amplifier. Change the coil in the amplifier section that requires excessive retuning and re-adjustment of the internal feedback potentiometer (R8, R27, R43, or R58).

Once the instrument is stabilized it is ready for the final test.

FINAL TEST -

1. Check regulated output voltage in power supply as directed in the PRELIMINARY TESTS & ADJUSTMENTS section of this manual.
2. Check oscillator voltage as directed in PRELIMINARY TESTS & ADJUSTMENTS.
3. Check oscillator stability and response to line voltage change as follows:
 - A. Apply a 400 cps, 1/2 volt signal to input terminals and tune instrument to same frequency with HALF BAND WIDTH control set at "145".
 - B. Adjust MILLIVOLTS meter to full scale with control "G".
 - C. Turn HALF BAND WIDTH control to "30" and repeak signal with FINE TUNING control. Adjust NEGATIVE FEEDBACK control for a full scale MILLIVOLTS meter reading.
 - D. Turn the line voltage down to 105 volts with the variable transformer. The meter reading normally drops to half scale. When the meter has stopped drifting, retune with the FINE TUNING control. The meter should read within 15% of full scale.

A change of greater than 15% is usually caused by a weak tube. Tubes V105 and V106 in the local oscillator, as well as tubes V9 and V10 in the meter circuit should be checked first.

4. Repeat the SELECTIVE AMPLIFIER ALIGNMENT procedure as a final selective amplifier alignment.
5. With no input to instrument, set frequency dial to midscale and the SET TO 100 dial to zero. Set the mechanical zero on the MILLIVOLTS meter to zero. The instrument must be at normal operating temperature when this adjustment is made.
6. Balance the modulator as explained in steps 1 through 11 of CALIBRATION PROCEDURE. Check control "C" butterfly capacitor, C107, to see that it is meshed equally on both sides. An unbalanced setting of this capacitor is an indication that modulator tubes V102 or V103 are unbalanced, modulation transformer (T101) is defective, or there are other defective parts in the modulator circuit. Refer to the TROUBLE SHOOTING section of this manual.
7. Check for carrier leakage. Balance modulator with HALF BAND WIDTH control at "145", METER SENSITIVITY control at "500", and frequency dial at "0". Turn METER SENSITIVITY to "25", rebalance modulator, turn control back to "500", and note MILLIVOLTS meter reading. Carrier leakage caused by the 20 KC signal from the local oscillator feeding through the power supply into the top deck will result in a higher MILLIVOLTS meter reading. Corrective steps are given in the TROUBLE SHOOTING section of this manual.

TEST PROCEDURE (Cont'd.)

FINAL TEST - (Cont'd.)

8. Check for hum as follows:
- A. Balance the modulator.
 - B. Set METER SENSITIVITY control to "500" and HALF BAND WIDTH control to "145".
 - C. Set the sub-panel meter to 5 volts with control "V". Flip lever switch "S" to the right.
 - D. Tune instrument at 60 cps for a maximum MILLIVOLTS meter reading. Adjust control "G" to obtain a full scale MILLIVOLTS meter indication.
 - E. Turn HALF BAND WIDTH control to "30" and retune instrument for a maximum MILLIVOLTS meter reading. Adjust NEGATIVE FEEDBACK control to obtain a full scale MILLIVOLTS meter reading.
 - F. Flip lever switch "S" to the left (vertical position) and turn the METER SENSITIVITY switch to "1".
 - G. Balance hum potentiometer (R159) in lower deck for a minimum MILLIVOLTS meter reading. The reading obtained should not be more than 0.08 millivolts.
 - H. Retune instrument to 120 cps and then 180 cps. The MILLIVOLTS meter reading again should not be more than 0.08 millivolts. Refer to the TROUBLE SHOOTING notes on hum removal.
9. Check resonance curves as follows:
- A. Check resonance curve for a 60 cps "hump". Set HALF BAND WIDTH control to "30"; METER SENSITIVITY at "500"; METER MULTIPLIER at ".5"; SET TO 100 at "100"; and connect a 400 cps, 1/2 volt, external source to the input terminals. Tune instrument to 400 cps and adjust control "G" for a full scale MILLIVOLTS meter deflection.

Gradually shift the external oscillator frequency and switch the METER SENSITIVITY control counterclockwise to maintain a MILLIVOLTS meter reading.

The meter indication should drop gradually. When the oscillator is 60 cps away from 400 cps, the gradual drop may show a hesitation or a small rise which is an indication of a 60 cps "hump" in the resonance curve.

The external oscillator must be tuned on both sides of 400 cps for this test. Refer to TROUBLE SHOOTING section of this manual for methods of eliminating this "hump".
 - B. Set instrument controls and connect external signal source as in step 9A except set HALF BAND WIDTH control at "145". Peak instrument for a full scale MILLIVOLTS meter reading at 400 cps.

Set external oscillator to 420, 460, 520, 545, and 700 cps. Record millivolt reading obtained at each frequency.

Plot the resonance curve on the broad sample curve given in Fig. 8. The plotted curve should fall within the two outside lines of sample curve.

Repeat this same process after recording the readings obtained by tuning the external oscillator to 380, 340, 280, 255, and 100 cps.
 - C. If the plotted curves fall outside the sample curve limits, it will be necessary to change the value of any one or all four resistors R18, R34, R74, and R77 across the toroid coils. Increasing a resistor value will sharpen the resonance curves in both broad ("145") and sharp ("30") HALF BAND WIDTH control positions. Adjustment of the broad curve must be completed before attempting adjustment of the sharp tuning curve.

The selective amplifier must be realigned after changing any of these four resistors.
 - D. Set HALF BAND WIDTH control to "30" (sharp) and plot resonance curve, using the procedure given in step 9B except take readings at 10, 20, 30, 40, 50, 60, and 70 cps above and below 400 cps. Particular attention should be given to the frequencies of 340 and 460 cps to be sure that a "hump" does not appear as explained in step 9A.

300A002 11/30/55

TEST PROCEDURE (Cont'd.)

FINAL TEST - (Cont'd.)

9D. (Cont'd.)

If the plotted curves fall outside the sample curve limits, it will be necessary to change the value of either or both resistors R75 and R76 in the feedback circuits of the two center stages. Decreasing the value of these resistors will sharpen the resonance curve.

The selective amplifier must be realigned after changing either resistor values.

Changing either or both of these resistor values will not affect the broad tuning curve.

If the two sides of the resonance curve are not symmetrical, repeat this step after very carefully peaking the instrument to 400 cps with the MILLIVOLTS meter. Refer to the TROUBLE SHOOTING section of this manual if the resonance curve is still not symmetrical.

10. Check harmonic distortion in the 300A as follows:

- A. Balance the modulator, set HALF BAND WIDTH control to "145", and switch METER SENSITIVITY to "500". Connect an external signal source with pure wave filter to input terminals and adjust to deliver a 0.5 volt signal at approximately 1600 cps.

The external signal source may have as high as 1.0% distortion provided a pure wave filter is used between this source and the 300A input. Refer to INSTRUMENTS REQUIRED FOR TEST PROCEDURE at the beginning of this TEST PROCEDURE section.

- B. Peak the 300A to the input signal and adjust the MILLIVOLTS meter to full scale with control "G". Retune instrument to the second harmonic (3200 cps) and set METER SENSITIVITY switch to "1".
- C. Adjust potentiometer R117 in the grid circuit of balanced modulator tubes (V102 and V103) for a minimum MILLIVOLTS meter reading. Rebalance the modulator and again adjust R117 for a minimum reading.

The remaining MILLIVOLTS meter reading should not be more than 0.2 millivolts. This reading is an indication of input signal distortion by the 300A.

Retune the 300A to the third harmonic (4800 cps) and note the MILLIVOLTS meter reading. This reading should again not be more than 0.2 millivolts.

- D. Repeat steps 10A and 10B with external signal source tuned to approximately 6300 cps and check second harmonic (12,600 cps) only. The MILLIVOLTS meter reading obtained should not be greater than 0.2 millivolts.

11. Check HALF BAND WIDTH variable selectivity control as follows:

- A. Connect a 400 cps, 0.5 volt, sine wave signal to the 300A input terminals. Tune instrument for a maximum reading with HALF BAND WIDTH control at "145". Set MILLIVOLTS meter to a reference point of ".8" with control "G". The METER SENSITIVITY switch should be on "500".
- B. Set HALF BAND WIDTH control to "30" and repeak the instrument with the FINE TUNING control. Adjust NEGATIVE FEEDBACK control for same ".8" MILLIVOLTS meter reference reading.
- C. Turn the HALF BAND WIDTH control for a maximum reading on the MILLIVOLTS meter and repeak the signal with the FINE TUNING control. The resultant MILLIVOLTS meter reading should be no greater than "1.0". If the reading is off scale, refer to the TROUBLE SHOOTING section of this manual.

12. Check MILLIVOLTS meter tracking as follows:

- A. Check mechanical zero as described in FINAL TEST step 5.
- B. Set the 300A to read voltages accurately as explained in steps 26A and 26B of PROCEDURE FOR CALIBRATION. Introduce a 400 cps signal and check MILLIVOLTS meter tracking against a meter with known calibration accuracy. The 300A voltmeter readings should be within $\pm 2\%$ of the full scale reading.

13. Check instrument sensitivity as follows:

- A. Set METER SENSITIVITY at "500", control "G" full clockwise, SET TO 100 control full clockwise, METER MULTIPLIER at ".5", and HALF BAND WIDTH control at "145".

TEST PROCEDURE (Cont'd.)

FINAL TEST - (Cont'd.)

13. (Cont'd.)

- B. Connect 400 cps from an external oscillator to input terminals and tune 300A for a maximum MILLIVOLTS meter reading. Adjust external oscillator for a full scale MILLIVOLTS meter reading. The input signal, as measured at the input terminals by an accurate external voltmeter, will normally be 0.25 volt or less. If external signal is 0.5 volt or less, sensitivity is satisfactory. See TROUBLE SHOOTING section if input voltage is too high.

14. Check main tuning dial frequency calibration as follows:

- A. Set frequency dial at "0" and FINE TUNING control with knob indicator straight up. Tune control "F" for a maximum MILLIVOLTS meter reading which will indicate that the internal oscillator frequency is 20 KC.

Rotor plates of "F" control trimmer should be approximately half meshed with stator plates when tuned to 20 KC. If they are not, or if internal oscillator cannot be tuned to 20 KC with control "F", it will be necessary to adjust variable capacitor C123 (See Fig. 4). If necessary, the values of fixed capacitors C112 and C113 may be adjusted. In older instruments having fixed capacitors C112 and C113 only, adjustment can be made only by changing these capacitor values.

When oscillator is on frequency in approximate center of tuning range for control "F", balance the modulator. Do not change setting of control "F" or the FINE TUNING control for remaining portion of this step.

Check frequency dial calibration with an external oscillator and a frequency standard or other frequency measuring device connected to the 300A input terminals. Adjust main tuning dial for a maximum MILLIVOLTS meter indication and note the dial reading. Repeat this process across the instrument frequency range.

Frequency dial calibration should be within $\pm 3\%$ at frequencies of 100 cps or higher and $\pm 5\%$ at frequencies below 100 cps.

To correct poor frequency dial tracking, pad R138 and R139 precision resistors and re-adjust variable capacitor C123 or change fixed capacitors C112 and C113 to bring oscillator on frequency. Series or parallel resistor pads may be used depending upon the tracking error to be corrected. Increasing either or both these resistor values will decrease oscillator frequency.

- B. Check and if necessary adjust oscillator injection voltage at V102 and V103 cathodes as directed in step 2 of PRELIMINARY TESTS & ADJUSTMENTS.

Turn frequency dial from top to bottom while measuring cathode injection voltage of V102 and V103. If injection voltage is not constant, reset variable capacitor C123 and bring oscillator on frequency with control "F". If range of C123 is not wide enough or C123 is not in a particular instrument, change capacity ratio of fixed capacitors C112 and C113. Increase the capacity of one while decreasing the capacity of the other an equal amount. The capacity change required must be experimentally determined.

Oscillator injection voltage may be adjusted for a slight rise at top of dial to compensate instrument frequency response.

15. Check frequency response as follows:

- A. Set HALF BAND WIDTH control to "145", connect external voltmeter and audio signal generator to 300A input terminals, and adjust for an input of 0.5 volt at 100 cps. Tune for a peak MILLIVOLTS meter reading and adjust control "G" for a reference reading of 0.9 on the 0 to 1.0 MILLIVOLTS meter scale with METER SENSITIVITY set to "500".
- B. Tune generator and 300A to 1 KC, 10 KC, and 16 KC while maintaining a constant input voltage. External voltmeter must be flat over this frequency range. The MILLIVOLTS meter readings should not vary from the reference point by more than $\pm 2\%$ of full scale. Correct a slight error by adjusting the internal oscillator frequency response as explained in step 14B. To correct a large error, see the TROUBLE SHOOTING section.

TEST PROCEDURE (Cont'd.)

FINAL TEST - (Cont'd.)

16. Check voltage calibration as follows:

- A. Balance the modulator, set HALF BAND WIDTH control to "145", set METER SENSITIVITY to "500", turn SET TO 100 control full clockwise, and set METER MULTIPLIER control to ".5".
- B. Introduce a measured 400 cps voltage of exactly 0.5 volt into the 300A input terminals. Tune for a peak and set MILLIVOLTS meter to full scale with "G" control.
- C. Turn control "V" full counterclockwise and adjust the mechanical zero of the VOLTS meter.
- D. Flip switch "S" to the right and adjust control "V" for a reading of 5 volts on the VOLTS meter.
- E. Tune instrument for a peak MILLIVOLTS meter reading at 60 cps. DO NOT CHANGE THE "G" CONTROL SETTING.
- F. The MILLIVOLTS meter reading should be full scale. If not, adjust the 60 cps signal for a full scale reading by padding either R106 or R107 in the voltage divider. Maintain a VOLTS meter reading of 5 volts with control "V" and pad R106 or R107 to obtain a full scale MILLIVOLTS meter reading.
- G. Recheck for a full scale reading at 400 cps as in step B except do not change the "G" control setting.
- H. Repeat steps B through G until a full scale reading is obtained for steps F and G by setting control "V" for 5 volts and tuning for a peak MILLIVOLTS meter reading.

17. Check the METER SENSITIVITY control as follows:

- A. Set METER MULTIPLIER to ".5", SET TO 100 control full clockwise, HALF BAND WIDTH control to "145", and METER SENSITIVITY control to "500".
- B. Connect output terminals of a precision attenuator to 300A input terminals. Use the correct value of attenuator load as specified by the attenuator manufacturer. This load may be connected across the 300A input terminals.
- C. Couple a 400 cps source to the attenuator input and adjust both attenuator and source to provide a 0.5 volt (500 millivolts) input signal to the 300A. The resulting signal level at the attenuator input must be maintained constant for the balance of this procedure.
- D. Peak the 300A for a maximum MILLIVOLTS meter indication and set control "G" for a full scale reading of 500 millivolts. DO NOT CHANGE THE SETTING OF CONTROL "G" FOR THE BALANCE OF THIS TEST.

E. Maintain a constant attenuator input level. Refer to the table on the right. Adjust the attenuator to introduce amount of attenuation given in column one, set the METER SENSITIVITY control to the position given in column two, and adjust the FINE TUNING control for a maximum MILLIVOLTS meter indication. In each case, the resulting MILLIVOLTS meter reading should be within $\pm 2\%$ of full scale.

Attenuation in db	METER SENSITIVITY Control Setting
0 500
6 250
14 100
20 50
26 25
34 10
40 5
46 2.5
54 1

This check is accurate only when the input level is maintained constant and a properly terminated precision attenuator is used.

The external audio oscillator, ac voltmeter, attenuator, and 300A should be grounded through the input test cable only. One side of the audio oscillator output cable should be grounded to oscillator chassis at the output terminals. A ground loop may cause erroneous readings when measuring low ac voltages.

TEST PROCEDURE (Cont'd.)

FINAL TEST - (Cont'd.)

18. Check the METER MULTIPLIER control as follows:

- A. Set METER MULTIPLIER to ".5", SET TO 100 control full clockwise, HALF BAND WIDTH control to "145", and METER SENSITIVITY control to "500".
- B. Apply exactly 0.5 volt (500 millivolts) at approximately 400 cps to the 300A input terminals. Peak the 300A for a maximum MILLIVOLTS meter indication and set control "G" for a full scale reading of 500 millivolts. DO NOT CHANGE THE SETTING OF CONTROL "G" FOR THE BALANCE OF THIS TEST.
- C. Set the METER MULTIPLIER and METER SENSITIVITY controls to the positions given in the following chart and note the MILLIVOLTS meter reading which should be as indicated in this same chart. Maintain a constant input signal level.

METER MULTIPLIER Control Setting	METER SENSITIVITY Control Setting	MILLIVOLTS Meter Reading
.5	500	Set level to full scale.
5	50	Full Scale, $\pm 1\%$.
50	5	Full Scale, $\pm 1\%$.
500	1	Half Scale, $\pm 2\%$.

19. In some older instruments, random noise may cause a slight erratic movement of the MILLIVOLTS meter pointer. Installation of resistor R73 (220 ohms, $\pm 10\%$, 1 watt) and capacitor C36 (500 μf , 15 vdcw, electrolytic) in the voltmeter circuit will eliminate this erratic movement. This network may be added on the top deck behind the MILLIVOLTS meter on a tie-point installed for that purpose. These components, when factory installed, are mounted on the underside of the top deck.
20. Install "CALIBRATION PROCEDURE" labels on the inside of the sub-panel door if they are not already there. These labels are available as a set from the factory under -hp- Stock No. 3A-43A.
21. Give the instrument a complete mechanical inspection. Check for missing or loose screws, poor solder connections, and missing or loose shields. Install bottom plates and replace in cabinet.
22. The metal bottom plate was fastened to the inside of the cabinet in some older instruments. Solder a flexible lead from this plate to a solder lug on the back of the lower deck. This is necessary to reduce lower deck hum pick up. In later instruments, this plate is fastened directly to the chassis bottom.
23. Replace ventilating screen over instrument back. Turn instrument on and let it run for a few hours. Check NEGATIVE FEEDBACK control setting from time to time during this time. No great change should be required in this setting as explained under HEAT RUN CHECK in this same section.

CIRCUIT MODIFICATIONS

GENERAL -

The circuit modifications that follow provide greater instrument stability; longer component life; ease of adjustment, testing, and repair; and better manufacturing procedures. Electrical performance specifications of the Model 300A have not changed and an older instrument will provide the same results as a new instrument. If an older instrument is functioning properly, there is no reason to make any circuit modifications.

WARNING

MAJOR MODIFICATIONS SHOULD BE ATTEMPTED ONLY WHEN THE NECESSARY TEST EQUIPMENT IS AVAILABLE FOR FINAL TESTING AND ADJUSTMENT OF THE MODIFIED INSTRUMENT. INSTRUMENT REQUIREMENTS FOR FINAL TESTING ARE GIVEN IN THE TEST PROCEDURE SECTION OF THIS MANUAL.

Instruments with Serial No. 1330 and above require no top deck modifications. Instruments with Serial No. 1610 and above require no modifications in either the top or bottom decks. The top deck in instruments with Serial No. 1610 and above is the same as that in instruments with Serial No. 1330 and above.

With certain exceptions in early instruments as noted, the modifications that follow will convert any Model 300A so that the top deck has a circuit equivalent to instruments with Serial No. 1330 or above and the lower deck has a circuit equivalent to instruments with Serial No. 1610 or above.

Components necessary for making circuit modifications are available from Hewlett-Packard. However, the quantity required will vary depending upon the age of the particular instrument involved.

IMPORTANT SCHEMATIC NOTICE

ALL CIRCUIT REFERENCES ARE FOR SCHEMATIC DIAGRAMS GIVEN IN FIGURES 3 OR 4 UNLESS OTHERWISE NOTED.

TOP DECK MODERNIZING PROCEDURE -

The following circuit changes will convert top decks in all instruments with Serial No. 1329 or below into the circuit given in Fig. 3. A complete list of parts for this modernization follows the last step in this procedure.

There are some instruments in the field having a combination of toroid coils for the first and fourth selective amplifier stages and solenoid type coils for the second and third stages. These solenoid type coils are wound on a round bobbin. Instruments with this coil combination usually have large rectangular shaped coil shields. Such instruments should be returned to the factory as field modernization is not practical.

1. Remove the four toroid coil shield cans. Install one watt, precision, carbon film, resistor of 479,000 ohms for R74, R18, R34, and R77 in parallel with L1, L2, L3, and L4 respectively. Add this resistor to all four toroid coils. Any other resistors found across a coil must be removed. Replace coil shields by pressing them firmly over base on chassis.
2. In some older instruments it will be necessary to replace any one or all four toroid coils. Drift will cause a loss in 20 KC selective amplifier gain. It will be necessary to advance the NEGATIVE FEEDBACK control farther and farther clockwise to obtain sufficient gain when the HALF BAND WIDTH control is set to "30". Amplifier alignment will be required when the NEGATIVE FEEDBACK control adjustment limit is reached. If the drift reoccurs repeatedly after amplifier alignment, coil replacement is required.

Refer to TROUBLE SHOOTING section and to HEAT RUN CHECK in the TEST PROCEDURE section for tests to determine if coil replacement is necessary.

3. Install resistors of 80,000 ohms, $\pm 1\%$, 1 watt (-hp- Stock No. 31-80K) for R10 and R59 in the negative feedback circuits for V1 and V7 respectively. Install resistors of 56,000 ohms, $\pm 1\%$, 1 watt (-hp- Stock No. 31-56K) for R28 and R44 in the negative feedback circuits for V3 and V5 respectively. The precision resistors available under the -hp- Stock numbers given above are the only ones recommended for this replacement.
4. Install -hp- Stock No. 24-68K resistors (68,000 ohms, $\pm 12\%$, 1 watt, composition) for R11, R29, R45, and R66 in the negative feedback networks for all four stages.

CIRCUIT MODIFICATIONS (Cont'd.)

TOP DECK MODERNIZING PROCEDURE - (Cont'd.)

5. Install -hp- Stock No. 31-2M resistors (2.0 megohms, ±1%, 1 watt, carbon film) for R9 and R57 in the positive feedback circuits of V1 and V7 respectively. Replace R4 and R51 (shown in Fig. 5 as being in series with R9 and R57) with wire jumpers.
6. Install -hp- Stock No. 31-1.63M resistors (1.63 megohms, ±1%, 1 watt, carbon film) for R26 and R42 in the feedback circuits for V3 and V5 respectively. Install -hp- Stock No. 23-150K resistors (150,000 ohms, ±10%, 1/2 watt, composition) for R75 and R76 in series with R26 and R42 respectively. These 1/2 watt resistors should be temporarily mounted since their value will probably be changed during alignment of the selective amplifier system.
7. Replace R1, R17, R33, and R50 with -hp- Stock No. 31-830K precision resistors (830,000 ohms, ±1%, 1 watt, carbon film). These resistors are in the grid circuits of V1, V3, V5, and V7 respectively.
8. Replace R3, R21, R37, and R53 with -hp- Stock No. 31-5000 precision resistors (5000 ohms, ±1%, 1 watt, carbon film). These resistors are in the cathode circuits of V1, V3, V5, and V7 respectively.
9. Replace R2, R20, R36, and R52 in the cathode circuits of V1, V3, V5, and V7 respectively with -hp- Stock No. 31-900 precision resistors (900 ohms, ±1%, 1 watt, carbon film).

Shunt each of these four resistors with an -hp- Stock No. 24-3900 resistor. These shunt resistors (3900 ohms, ±10%, 1 watt, composition) should be temporarily installed as their final values are determined during alignment and adjustment of the selective amplifier stages.

10. Install C37, C38, C39, and C40 (10 μf, ±10%, 500 vdcw, mica, -hp- Stock No. 14-10) in parallel with R11, R29, R45, and R60 respectively.
11. Replacement of NEGATIVE FEEDBACK and HALF BAND WIDTH four gang control potentiometers and their shielded connecting cables is recommended for complete modernization. This is particularly important in instruments with shielded cables that do not have an insulating outer cover.
12. In instruments with Serial No. 1106 or below, install R73 resistor (220 ohms, ±10%, 1 watt) in series with the MILLIVOLTS meter movement. Connect C36 (500 μf, 15 vdcw electrolytic) capacitor in parallel with this series combination. The circuit before this modification is shown in Fig. 7A and afterwards in Figs. 3 and 7B.

This network is mounted on the top deck behind the MILLIVOLTS meter on a tiepoint installed for this purpose. The addition of this network minimizes meter pointer unsteadiness due to random noise. These components when factory installed, are mounted on the underside of the top deck.

PARTS REQUIRED FOR COMPLETE MODERNIZATION OF A TOP DECK -

The exact number of parts required will be dependent upon instrument age. Maximum quantities are given below.

DESCRIPTION	QUANTITY	-hp- STOCK NO.
Resistors, Precision; fixed, carbon film, axial leads, ±1%, 1 watt,		
900 ohms	4	31-900
5000 ohms	4	31-5000
56,000 ohms	2	31-56K
80,000 ohms	2	31-80K
479,000 ohms	4	31-479K
830,000 ohms	4	31-830K
1.63 megohms	2	31-1.63M
2.0 megohms	2	31-2M
Resistor; fixed, composition,		
150,000 ohms, ±10%, 1/2 watt	2	23-150K

300A0002 11/30/53

CIRCUIT MODIFICATIONS (Cont'd.)

PARTS REQUIRED FOR COMPLETE MODERNIZATION OF A TOP DECK - (Cont'd.)

<u>DESCRIPTION</u>	<u>QUANTITY</u>	<u>-hp- STOCK NO.</u>
Resistors; fixed, composition, $\pm 10\%$, 1 watt, 220 ohms	1	24-220
3900 ohms	4	24-3900
68,000 ohms	4	24-68K
Capacitor; fixed, mica, 10 μf , $\pm 10\%$, 500 vdcw	4	14-10
Capacitor; fixed, electrolytic, tubular, 500 μf , 15 vdcw	1	18-5
NEGATIVE FEEDBACK and HALF BAND WIDTH control assemblies with shielded and insulated connecting harness	1	3A-15
Toroid coil tuned circuit assembly; 20 KC	4	3A-62

BOTTOM DECK MODIFICATION PROCEDURE -

Modifications that follow are divided into separate procedures since it may not be necessary or desirable to incorporate all modifications unless required. After some modifications have been completed, little or no instrument adjustment is required while after other modifications extensive instrument adjustments are required.

Instrument age will determine parts requirements for a particular modification. All possible parts required are identified by -hp- stock number as well as a complete description. Determine parts requirements by reading through a modification while referring to instrument to be changed. Parts required can then be secured from -hp- or a local source.

MODIFICATION TO REDUCE CARRIER LEAKAGE -

When incorporated in instruments with Serial No. 1369 or below, this modification will provide reduced carrier leakage. Step 7 of the FINAL TEST procedure gives the method of checking carrier leakage. Instruments with Serial No. 1370 and above had this modification included during manufacture.

This modification can be incorporated at any time and requires no special instrument adjustments following completion. Any instruments with a single three section capacitor for C125, C126, and C127 should have this modification incorporated before or when replacement of this electrolytic is necessary.

Basically three mechanical changes are made in the instrument wiring when incorporating this revision. Coupling in the common electrolytic capacitor for C125, C126, and C127 is eliminated in older instruments by installing separate capacitors. Leads carrying B+ are eliminated in any cabling crossing the front of the chassis. Resistor R154 is moved to a new mounting location to provide better circuit isolation.

1. Chassis With a Single 3 Section Capacitor - Disconnect all wires (usually five) connecting to positive terminals of three section electrolytic capacitor for C125, C126, and C127. Trace all of these wires through the instrument cabling and disconnect other end of wire. Remove wires completely or clip them off at point of entry into cabling.

Chassis With 3 Separate Capacitors - Potentiometer R123 (control "R") will have two wires connected to its center terminal. One of these wires goes through the cabling to screen grid pin 6 of V102 and V103 as well as transformer T101. This wire must remain in the instrument as is. Trace the other wire connecting the center terminal of R123 to one end of R154. Disconnect both ends of this second wire and remove completely or clip off ends at point of entry into cabling.

Locate the common junction of power resistors R148, R149 (both 10,000 ohms), and two wires. The other end of one of these wires connects to a tie lug junction of R144, R145, and C127 near the V105 tube socket. The second wire terminates at the cathode of series voltage regulator tube V109.

CIRCUIT MODIFICATIONS (Cont'd.)

BOTTOM DECK MODIFICATION PROCEDURE - (Cont'd.)MODIFICATION TO REDUCE CARRIER LEAKAGE - (Cont'd.)

1. (Cont'd.)

If this second wire enters cabling across rear of instrument, it need not be changed and step 4 can be eliminated. However, if this wire enters cabling across front of instrument, disconnect and clip off both ends of wire at point of entry into cabling.

2. Add or move capacitors C125, C126, and C127 so that they are connected electrically as shown in Fig. 4 and as described below. The required tubular electrolytic capacitor (10 μ f, 450 volts) is available **under -hp- Stock No. 18-10.**

These three capacitors have their negative terminals connected to a convenient chassis ground and their positive terminals connected as follows:

- C125 - to tie point junction of R121, T101 transformer, and screen grid pins 6 for V102 and V103.
- C126 - to tie point junction of R136 and R137 in V104 plate circuit.
- C127 - to tie point junction of R144 and R145 in V105 plate circuit.

Refer to Fig. 11 for approximate mounting positions.

It will be necessary to add all three of these capacitors to any instrument from which a single triple section electrolytic capacitor is removed as directed in step 1.

3. Remove R154 (15,000 ohms, $\pm 10\%$, 2 watts, **-hp- Stock No. 25-12K**) from present mounting terminals and reconnect as directed in the procedure that follows.

Locate the junction of R144 and R145 which is usually a terminal on one end of a dual tie lug strip. The opposite end of this tie lug strip may be vacant or have other components and wires connected to it. Any such connection to this second terminal must be moved to an electrically equivalent point elsewhere in the instrument. If this is not convenient, mount a new tie lug close enough to provide a mounting terminal for one end of R154 when the other end is connected to the tie lug junction of R144 and R145.

Mount R154 between the two tie lugs just identified. This connects one resistor end to the junction of R144 and R145 and the other end to a vacant insulated tie lug. Connect a wire between this vacant tie lug and circuit point to which screen grids (pin 6) of V102 and V103 are connected.

4. Connect a wire between power supply series regulator tube (V109) cathode and junction of R144, R145, and R154. This wire need not be added if, in step 1, it was not necessary to remove a wire connecting these two points together. If in doubt, add this second wire as no harm can be done by doing so.

POWER SUPPLY MODIFICATION -

The power supply for all instruments is fundamentally the same. However, there have been minor circuit changes and different tube types used for power supply circuitry as shown by Figs. 4, 6, 7C, and 7D.

As long as a power supply is functioning properly as determined by tests given in the FINAL TEST procedure section, there is no need to attempt any type of power supply modernization. Replace power supply tubes with the same types found in an instrument.

If the power supply in a particular instrument becomes erratic or fails repeatedly, dismantle the power supply and rewire according to Fig. 4 schematic diagram. Install new parts throughout, change tube sockets as required, and if necessary change the power transformer.

The power transformer change will be a must when modernizing extremely old instruments having a type 2A3 tube for the series regulator tube.

After rebuilding a power supply, complete steps 1 and 2 of PRELIMINARY TESTS & ADJUSTMENTS and check harmonic distortion as described in step 10 of FINAL TEST procedure. Measure local oscillator frequency with main tuning dial at "0" and FINE TUNING control vertical. The local oscillator should tune to 20 KC with control "F" in the approximate center of its tuning range.

CIRCUIT MODIFICATIONS (Cont'd.)

BOTTOM DECK MODIFICATION PROCEDURE - (Cont'd.)OTHER LOWER DECK MODIFICATIONS -

The following changes should be incorporated in instruments only when required or applicable.

Replacement of any frequency determining components such as C112, C113, R138, or R139 in steps 2 and 3 will necessitate a complete frequency calibration according to step 14 and 15 of FINAL TEST procedure in this manual.

1. This modification applies to instruments with Serial No. 947 and below. Instruments with higher serial numbers had this component change made during manufacture.

Replace the 3 watt, 115 volt lamp (R140) in V105 cathode circuit with a 10 watt, 230 volt lamp available under -hp- Stock No. 211-29. Complete step 2 of PRELIMINARY TESTS & ADJUSTMENTS. Resistor R143 will be a fixed resistor in instruments requiring this change. The series padding resistor value will be from 0 to 1000 ohms. If this adjustment range is not adequate for a particular lamp bulb, reject the bulb and try a different one.

2. Local oscillator frequency determining capacitors C112 and C113 should be silver mica or ceramic type units with low or zero temperature coefficients.

Silver mica capacitor -hp- Stock No. 15-27 is recommended for replacement of C112 and Stock No. 15-90 for replacement of C113.

3. Oscillator frequency stability can be improved in some older instruments by replacing frequency determining resistors R138 and R139. If, in a particular instrument, these special precision resistors (7000 ohms, wire wound) are found to have a stamped marking of "7K", they should be replaced with new type -hp- Stock No. 3A-26A which have the same resistance but no stamped markings. These are wound with a new type wire having an improved temperature coefficient.

TROUBLE SHOOTING

GENERAL -

The notes given in the TROUBLE CHART that follow are based on -hp- experience. The more common troubles, their symptoms, and remedy are given.

It is beyond the scope of this manual to include all possible or obscure and rare troubles. If an instrument develops trouble symptoms not covered by this chart, repair analysis will be simplified if the CIRCUIT DESCRIPTION given in this manual is used to obtain a complete understanding of the instrument circuitry.

All circuit references refer to Figs. 3 and 4 unless otherwise noted. Signal, ac, or dc voltages when mentioned here, are measured between the indicated points and the chassis unless specified otherwise.

Any tubes with standard RETMA characteristics may be used for tube replacements as explained in the TUBE COMPLEMENT & TUBE REPLACEMENTS section. In a great number of cases, instrument trouble can be traced to a defective tube. Modulator tubes V102 and V103 must be selected for balance and freedom from hum, noise, and distortion. Oscillator tubes V105 and V106 or meter tubes V9 and V10 occasionally must be selected for minimum effect with line voltage changes.

Measurement of power supply dc current will, in many cases, aid in localizing the cause of instrument failure. The total B+ current, measured at the power transformer center tap, will normally be approximately 75 ma. The upper deck B+ current, measured on either side of R157, will normally be approximately 20 ma. Measure the combined plate and screen current for the series regulator tube V109 to determine the regulated B+ current delivered to the lower deck. This lower deck current will normally be approximately 55 ma. These current figures are shown on the schematic diagram of Fig. 4 at the points of measurement.

TROUBLE CHART -

TROUBLE SYMPTOM	CAUSE AND/OR REMEDY
No dc voltage from power supply.	Fuse F101 burned out.
	Rectifier tube V110 defective.
	Filter capacitors C119, C120, or C121 and C122 shorted.
	Short circuit in power supply distribution system.
	Choke L102 or L103 open.
	Power transformer T103 defective.
No B+ from regulated portion of power supply.	No dc input to regulated supply.
	Tubes V107, V108, or V109 defective.
	Power transformer T103 defective.
	Capacitor C127 defective.
	Short circuit in regulated power supply distribution system.
Regulated B+ output is high and cannot be set to 240 volts with R152 control. Supply also will not regulate.	Any one or all tubes V107, V108, and V109 defective.
	Any one of several resistors in voltage regulator circuit have increased in value or opened up.
Regulated B+ output is normal (240 volts) but power supply will not regulate with a change in line voltage.	Tube(s) V107, V108, and/or V109 defective.
	Defective rectifier tube V110.
	Power transformer T103 defective.
	Electrolytic capacitors C119, C120, C121, C122, or C127 defective.
Regulated B+ output is low and cannot be set to 240 volts with R152 control. Supply also will not regulate.	Tube(s) V107, V108, and/or V109 defective.
	Rectifier tube V110 defective.
	Power transformer T103 defective.
	Electrolytic capacitors C119, C120, C121, C122, or C127 defective.
	Capacitor C124 (0.05 μ f) defective.
	Shorted B+ wiring in lower deck.
	Shorted tube anywhere in lower deck.
Tube in lower deck drawing excessive plate current due to a defective coupling capacitor.	

TROUBLE SHOOTING (Cont'd.)

TROUBLE CHART - (Cont'd.)

TROUBLE SYMPTOM	CAUSE AND/OR REMEDY
Oscillator dead when measured at junction of R138, R142, and C117.	Tube V105 (6J7) or V106 (6F6) defective. Cathode lamp (R140) unscrewed or open. Grid cap for V105 disconnected. Shorted plates in tuning capacitor C111. Trimmer capacitors C114, C115, or C123 shorted. Capacitors C112, C113, C116, C117, C118, or C127 shorted. Resistors R138 or R139 defective. Capacitors C116, or C117 open. Resistors R144, R145, R148, or R149 open. Failure of plate or heater supplies for tubes V105 and V106.
No oscillator voltage at cathodes of modulator V102 and V103.	See preceding trouble symptom. Capacitor C118 open. Tube V102 or V103 shorted.
Excessive oscillator voltage with control R143 not effective.	Control R143 or resistor R142 open. Socket for R140 lamp shorted. Lamp R140 resistance may be too low. Replace with 10 watt, 230 volt lamp.
Oscillator output is distorted.	Tube V105 (6J7) or V106 (6F6) defective. Resistor R141 defective. Incorrect dc voltages on these tubes due to defective resistors, leaky feedback capacitor C117 or coupling capacitor C116.
Oscillator operating at wrong frequency for some reason other than mal-adjustment of frequency determining components.	Fixed capacitors C112 or C113 defective. Variable capacitor C114 or C123 disconnected. Frequency determining resistors R138 or R139 defective. A drop of solder can very easily short out a section of these wire wound resistors.
MILLIVOLTS meter dead.	Defective tube anywhere in upper deck. Defective meter movement. Defective coupling or by-pass capacitors in upper deck. No heater or B+ voltage in upper deck due to defective cable or connecting plug. Shorted or open signal cable from lower deck. Defective tube for any one or all stages V101 through V106. Transformer T101 defective. Local oscillator not functioning. Defective coupling or by-pass capacitor. Power supply failure. Control potentiometer R108 defective. Switch S102 defective. METER MULTIPLIER and/or METER SENSITIVITY attenuator defective.
Low gain in selective amplifier.	Defective tube in selective amplifier. Low B+ from power supply. Defective coupling, feedback, and/or by-pass capacitor in amplifier. Open 10 μ f decoupling capacitor for C8, C15, C20, and/or C31 which will cause degenerative feedback. Tuned circuits out of alignment.
Low gain in selective amplifier only in the sharp (30) position.	Tuned circuits out of alignment. Potentiometers R8, R27, R43, and R58 in feedback circuits are out of adjustment.

TROUBLE SHOOTING (Cont'd.)

TROUBLE CHART - (Cont'd.)

TROUBLE SYMPTOM	CAUSE AND/OR REMEDY
Amplifier gain too high in sharp tuning (30) position only.	Potentiometers R8, R27, R43, and R58 in feedback circuits are out of adjustment.
	Grounded terminal on potentiometer R8, R27, R43, or R58.
	Grounded terminal on any one section of either of the two 4 gang potentiometers for NEGATIVE FEEDBACK and HALF BAND WIDTH controls. In some older instruments, the top deck bottom plate did not have an insulating strip and occasionally the control terminals short out on the bottom plate.
	One or more of the shielded cables to either of the 4 gang potentiometers may be shorted internally. This is more likely to happen in older cables having rubber insulation.
Top deck oscillating. Oscillation usually more pronounced with HALF BAND WIDTH control in the sharp position.	Poorly grounded toroid coil shield cans. Scrape paint or trim off insulating paper as required to obtain a good contact between can and lid.
	Improperly tuned and adjusted amplifier stage as explained in Alignment of Selective Amplifier under Test Procedure.
	Potentiometer R8, R27, R43, and/or R58 in feedback circuit, out of adjustment.
	Component in any feedback circuit, open or shorted to ground.
	Capacitors C37, C38, C39, and/or C40 (10 muf), defective or missing.
	Shorted terminal or open section in 4 gang potentiometers for NEGATIVE FEEDBACK and HALF BAND WIDTH controls.
	One or more of the shielded cables to either of the 4 gang potentiometers may be shorted internally. This is more likely to happen in older cables having rubber insulation.
Modulator will not balance according to CALIBRATION PROCEDURE instructions.	Modulator tubes V102 and V103 must be selected so that a balance can be obtained with controls "C" and "R" in the approximate center of their tuning range. Potentiometer R117 should also be in the approximate center of its range for this check and will then have to be readjusted according to instructions in FINAL TEST step 10.
	If capacitor "C" (C107) or resistor "R" (R123) balance away off center, temporarily transpose tubes V102 and V103 and note position of controls when balanced. If control position has shifted to the other side of center, tubes V102 and V103 are at fault. If there is no change in control position, check components in modulator circuit other than tubes V102 and V103.
	Modulation transformer T101 defective.
	Open or off value resistor for R122 or R124 which are normally 10,000 ohms.
	Capacitor C107 for control "C" shorted due to damaged plates or foreign conductive material between plates.
	Potentiometer R123 for control "R", open.
	Potentiometer R117, open or shorted.
	Open or off value resistor for R116 or R118 which are normally 82,000 ohms.

TROUBLE SHOOTING (Cont'd.)

TROUBLE CHART - (Cont'd.)

TROUBLE SYMPTOM	CAUSE AND/OR REMEDY
No 60 cps calibrating signal with "S" lever switch (S102) flipped to the right and a VOLTS meter reading of 5 volts.	Resistor R106 open.
	Defective "S" lever switch (S102).
	Contacts dirty in "S" lever switch.
	Short circuit across resistor R107.
The 60 cps calibrating signal measures 5 volts instead of 0.5 volt on MILLIVOLTS meter.	Resistor R107 open.
	Short circuit across resistor R106.
Excessive carrier leakage as explained in FINAL TEST step 7.	Hum balance potentiometer R159 or ground strap to this potentiometer may be open.
	By-pass capacitor C109 on V104 cathode may be grounded to ground side of peaking coil L101 or to the chassis at the tube socket. Connect to point providing minimum carrier leakage.
	Single ground wire from METER SENSITIVITY attenuator may be grounded at V104 tube socket or ground side of L101. Connect to point giving minimum carrier leakage.
	Instruments with Serial No. 1369 and below should be modernized to reduce carrier leakage as given in the CIRCUIT MODERNIZATIONS section of this manual.
Poor line voltage response as explained in FINAL TEST step 3.	If V9 and V10 in the MILLIVOLTS meter circuit are weak, the meter reading will drop off when the line voltage drops. Select tubes for replacement that produce minimum change in the meter reading.
	Tubes for V101, V102, V103, and/or V104 may be weak. Changes in line voltage have little effect on the selective amplifier stages.
	If tubes for V105 and V106 in the oscillator are weak, excessive oscillator frequency change and a loss in injection voltage will result when the line voltage is reduced. Select tubes for replacement that produce minimum change in the MILLIVOLTS meter reading.
	Loss of power supply regulation will have the same effect as weak tubes for the oscillator.
Excessive drift of the tuned circuits as indicated by the necessity of making repeated adjustments of the NEGATIVE FEEDBACK control.	Instruments with Serial No. 1329 and below should be modernized according to the TOP DECK MODERNIZING PROCEDURE given in the CIRCUIT MODIFICATIONS section of this manual.
	Defective toroid coil for L1, L2, L3, and/or L4.
	Selective amplifier improperly aligned.
	Replacement toroid coil not aged long enough. See HEAT RUN CHECK given under TEST PROCEDURE.
Excessive hum as determined by FINAL TEST step 8 in TEST PROCEDURE section of this manual.	Toroid coils will occasionally deteriorate with age, particularly in older instruments, and become unstable. It may be necessary to replace any one or all four coils.
	Defective tube for any one of V101 through V106 in the lower deck or any 6SJ7 tube in the selective amplifier.
	Stray coupling between C102 (0.5 μ f) in V101 cathode circuit and heater leads. Separate leads and capacitor as far as possible.
	Pin 1 of some tube sockets are grounded to the chassis. Check these grounds for a possible loose connection. Check all cable and attenuator ground connections.
	In some older instruments, the lower deck bottom plate was fastened to the inside of the cabinet. Connect a flexible wire between this plate and the bottom chassis.

TROUBLE SHOOTING (Cont'd.)

TROUBLE CHART - (Cont'd.)

TROUBLE SYMPTOM	CAUSE AND/OR REMEDY
Excessive hum as determined by FINAL TEST step 8 in TEST PROCEDURE section of this manual. (Cont'd.)	Defective power supply filter capacitors.
	Check ground connections of electrolytic capacitors.
	Hum balance potentiometer (R159) is not properly adjusted.
	The METER MULTIPLIER ground lead should be connected to the ground side of the input gain control R108. A second insulated wire from R108 ground terminal should then run down through the chassis hole and connect to a ground lug on V102 socket. Remove any panel ground connection at the ground side of R108.
Resonance curve has 60 cps "hump" as determined by FINAL TEST step 9A in TEST PROCEDURE section.	Defective tube in V101, V102, V103, V104, V105, and/or V106 positions. A defective type 6SJ7 tube for first two or three tubes in the selective amplifier can also produce the 60 cps "hump".
Resonance curve not symmetrical.	The braided shielding on the cables connecting to the two four gang potentiometers is not insulated in some older instruments. Ground loops resulting from this exposed shielding may cause a nonsymmetrical response curve. Replace complete assembly consisting of controls with insulated cables.
	Peaking coil L101 may be open.
	Defective four gang potentiometer for NEGATIVE FEEDBACK control.
	Top deck oscillating. See "Top deck oscillating" in this chart.
Excessive harmonic distortion. See step 10 of FINAL TEST in TEST PROCEDURE section.	Any one or all tubes V101 through V106 may be defective.
	Pin 1 of V101 tube socket may not be grounded.
	Modulator tubes V102 and V103 may be mismatched.
	Modulation transformer T101 may be unbalanced, replace.
	Potentiometer R117 may be incorrectly adjusted. Refer to step 10 of FINAL TEST in the TEST PROCEDURE section.
	Peaking coil L101 may be open.
	Leaky coupling capacitor or open by-pass capacitor in lower deck.
Variable selectivity will not pass test given in step 11 of FINAL TEST in TEST PROCEDURE section.	Replace the four gang potentiometer which functions as the HALF BAND WIDTH control. The control only, or an assembly which includes both four gang potentiometers and all shielded connecting cables can be obtained from the factory.
Excessive MILLIVOLTS meter tracking error.	Check and adjust mechanical zero on meter.
	High residual emission of type 6H6 tube used for V10. Replace this tube.
	Heater to cathode leakage in 6SN7GT tube used for V9. Replace tube.
	Capacitor C35 (0.05 μ f) leaky.
Low instrument sensitivity as determined in step 13 of FINAL TEST in TEST PROCEDURE section.	Low injection voltage from local oscillator. See FINAL TEST step 2.
	Weak or defective tubes for any one or all tubes V101 through V104.
	Adjust regulated B+ voltage. See FINAL TEST step 1.
	Defective T101 modulation transformer.
	Capacitors C103, C108, and/or C110 may be defective.

TROUBLE SHOOTING (Cont'd.)

TROUBLE CHART - (Cont'd.)

TROUBLE SYMPTOM	CAUSE AND/OR REMEDY
Low instrument sensitivity as determined in step 13 of FINAL TEST in TEST PROCEDURE section. (Cont'd.)	Check all tubes for abnormal plate, screen, grid, cathode, and heater voltages.
	Defective attenuator for METER MULTIPLIER or METER SENSITIVITY control.
	Tubes V9 and/or V10 defective or weak.
	Defective MILLIVOLTS meter movement.
	Peaking coil L101 may be open.
	Low gain in selective amplifier. This is covered elsewhere in this TROUBLE CHART.
Main frequency dial off calibration as determined in step 14 of FINAL TEST in TEST PROCEDURE section of this manual.	Variable "F" control capacitor C114 may be disconnected.
	Variable capacitor C123 may be disconnected.
	Defective fixed capacitors C112 and/or C113.
	Tubes V105 and/or V106 defective.
	Wire wound frequency determining resistor R138 or R139 off value due to shorted turns. Look for a drop of solder on resistor.
Poor frequency response.	Oscillator output not flat over the range of the instrument. See step 14B of FINAL TEST in TEST PROCEDURE section.
	Coupling capacitors C101, C103, and/or C105 defective.
	Check for defective component in circuits ahead of input to modulator tubes V102 and V103.
Voltage calibration error. See step 16 of FINAL TEST in TEST PROCEDURE section.	Operator failed to turn input gain control (SET TO 100) full clockwise to MAX, or to set the HALF BAND WIDTH control to same position used for calibration. Operator failed to adjust to the same reference level with the NEGATIVE FEEDBACK control when changing selectivity.
	Defective VOLTS meter movement.
	Wirewound resistors for R106 and R107 have changed value, opened up, or are shorted. Pad to proper ratio by connecting resistor in parallel with R106 or R107. A drop of solder can short out a section in one of these resistors.
	Adjust VOLTS meter to zero with instrument turned off or control "V" full counterclockwise.
Unsteady MILLIVOLTS meter indication.	Check for noise in main and regulated power supplies. Check power supply electrolytic capacitors, tubes and resistors.
	Check local oscillator for a steady output as directed in step 4 of PRELIMINARY TESTS & ADJUSTMENTS in the TEST PROCEDURE section of this manual.
	Check electrolytic decoupling capacitors in top deck.
	Check coupling, feedback, and by-pass capacitors in both chassis.
	Check for a noisy tube anywhere in instrument.
	Refer to step 12 of TOP DECK MODERNIZATION PROCEDURE in the CIRCUIT MODIFICATIONS section of this manual.
A 20 KC external signal source operating near the 300A may radiate a signal directly into the selective amplifier of the 300A and cause a beat effect.	
Residual MILLIVOLTS meter reading.	Mechanical zero set on MILLIVOLTS meter is out of adjustment.
	Residual emission or hum in V10 type 6H6 tube. Replace with selected tube.
	Hum in V9 type 6SN7 tube.
	Top deck oscillating. See "Top deck oscillating" in this same section.

TROUBLE SHOOTING (Cont'd.)

TROUBLE CHART (Cont'd.)

TROUBLE SYMPTOM	CAUSE AND/OR REMEDY
Residual MILLIVOLTS meter reading. (Cont'd.)	Type 6Y6 tube for V109 in power supply is oscillating. Install resistor R164 in series with the screen grid.
	Oscillating reference tube for V107 (OAZ or neon bulb) in power supply. Replace.
	Excessive hum. See corrective steps given under this heading elsewhere in this chart.
	Leaking 0.05 μ f coupling capacitor for C35 in the meter circuit.
	A 20 KC external signal source operating near the 300A may radiate a signal directly into the selective amplifier of the 300A.
Hum balance potentiometer, R159, smoking or burned out.	Heater lead or tube socket heater pin shorted to the chassis.
Microphonics	Microphonic tube anywhere in instrument. Modulator, oscillator and output amplifier tubes in lower deck as well as first 2 or 3 tubes in selective amplifier should be checked first.
	Cathode lamp (R140) in oscillator may be microphonic or loose in socket.
	Loose center contact in lamp socket for R140. Replace socket.
	Poor ground connection at negative terminal of an electrolytic capacitor.
	Modulation transformer T101 defective.
	Poor ground connection or solder joint anywhere in instrument. Intermittant short circuit.
	Loose connection to MILLIVOLTS meter or defective meter movement.
Defective resistor anywhere in instrument.	

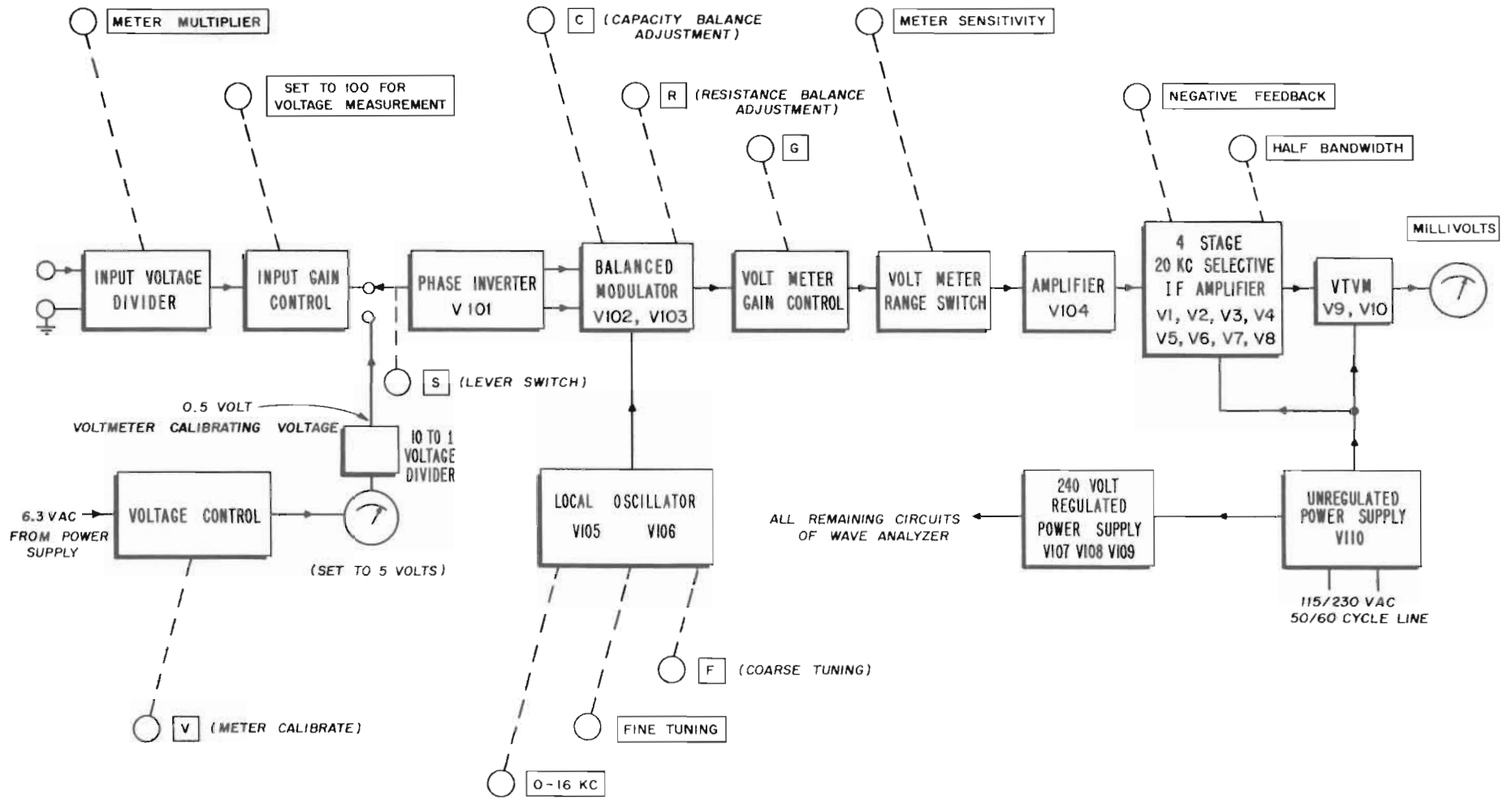
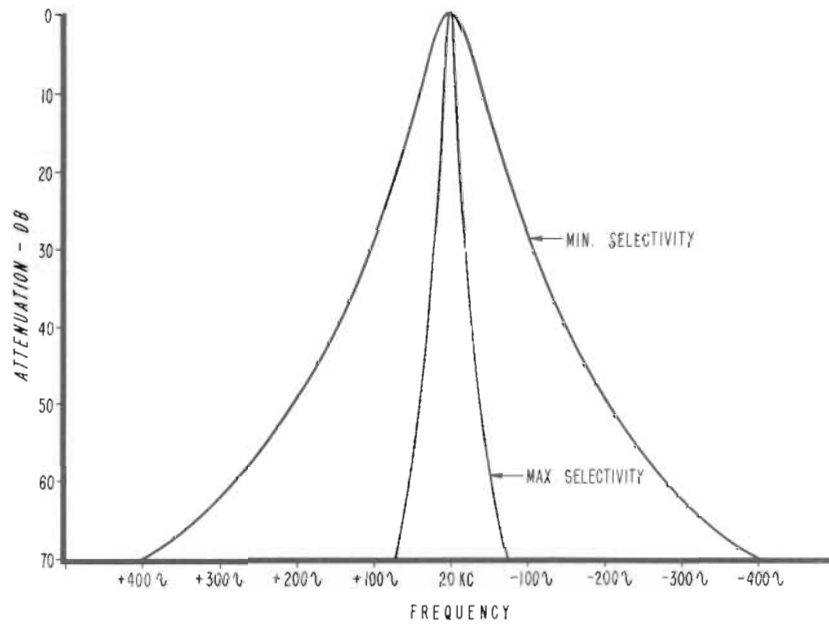
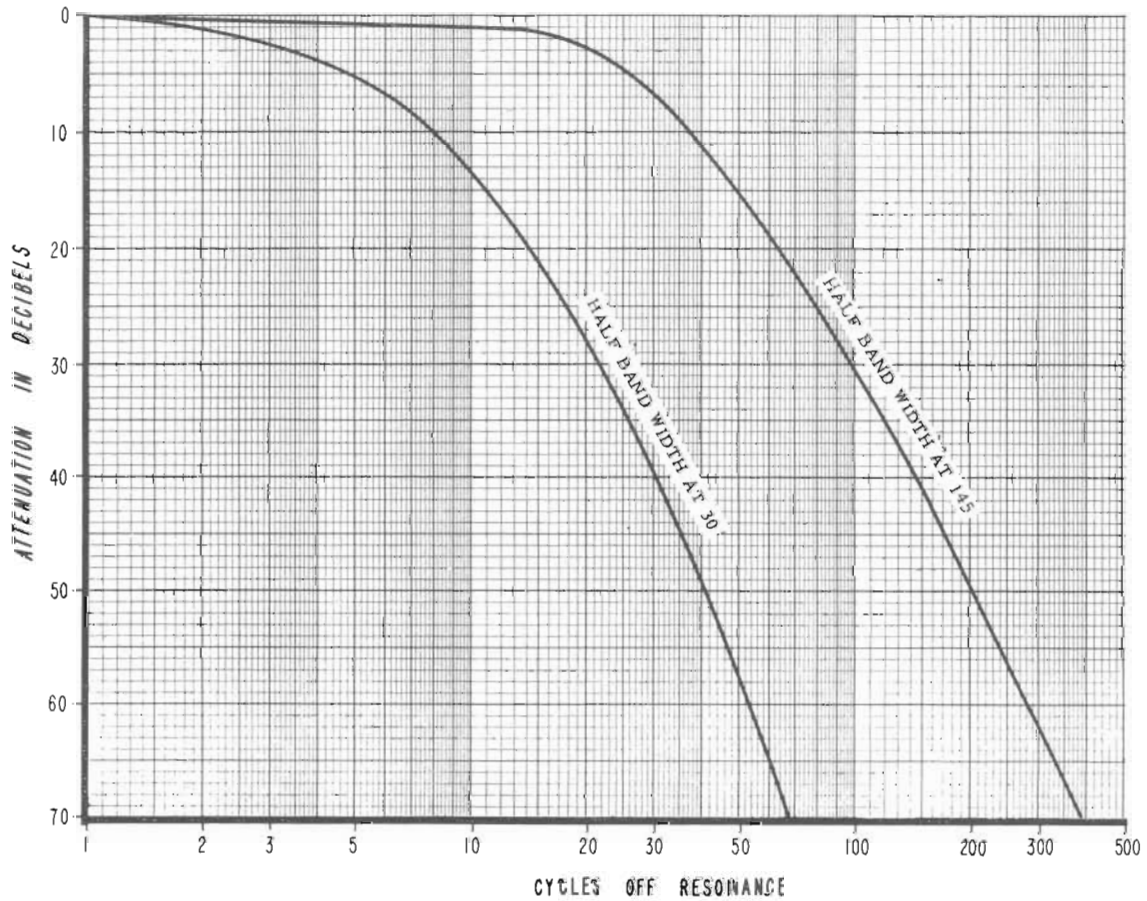

Fig. 1. Model 300A Block Diagram



Selectivity Characteristics of Model 300A Amplifier



Half Band Width Characteristics of Model 300A Amplifier

Fig. 2. Characteristics of Selective Amplifier System

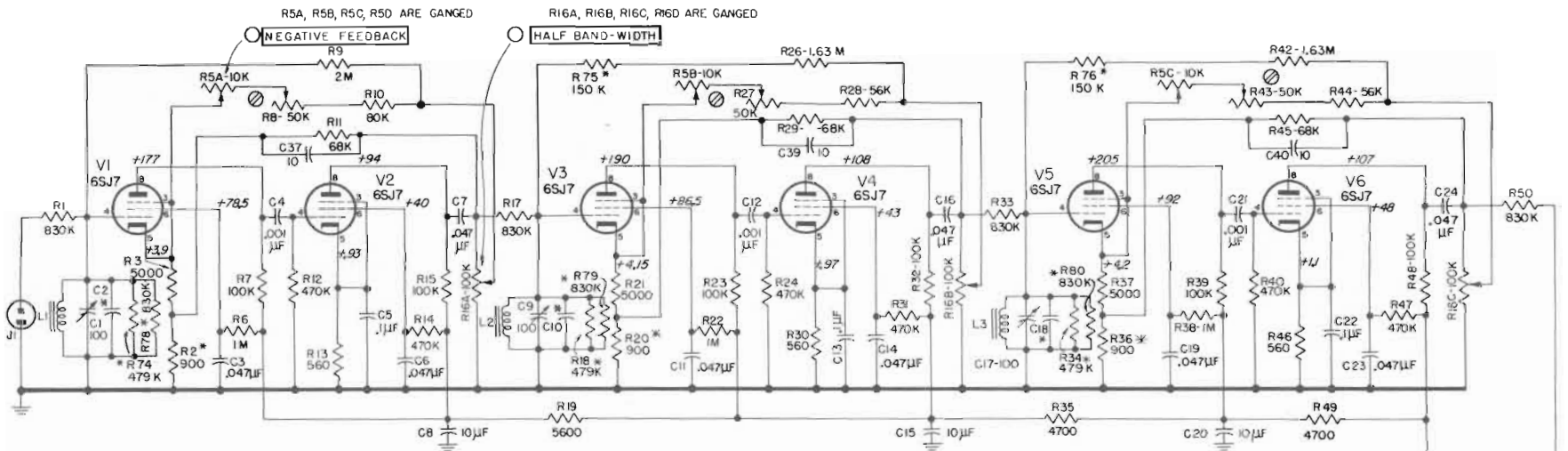

NOTES:
(THESE NOTES ALSO APPLY TO THE SCHEMATIC OF MODEL 300A MODULATOR, OSCILLATOR, & POWER SUPPLY SECTIONS.)

- CONDITIONS OF DC VOLTAGE MEASUREMENT:
- 115/230 V, 60~ POWER SUPPLY
 - MEASURED BETWEEN INDICATED POINTS & CHASSIS WITH A VOLTMETER OF 122 MEGOHMS INPUT RESISTANCE.
 - PANEL CONTROLS SET AT ANY POSITION

○ PANEL CONTROL

⊗ SCREWDRIVER CONTROL

⊥ CHASSIS

CAPACITANCE VALUES GIVEN IN μF UNLESS OTHERWISE NOTED.

K=1000 OHMS

M=1 MEGOHM

* ELECTRICAL VALUE ADJUSTED AT THE FACTORY; AVERAGE VALUE SHOWN. PART MAY BE OMITTED.

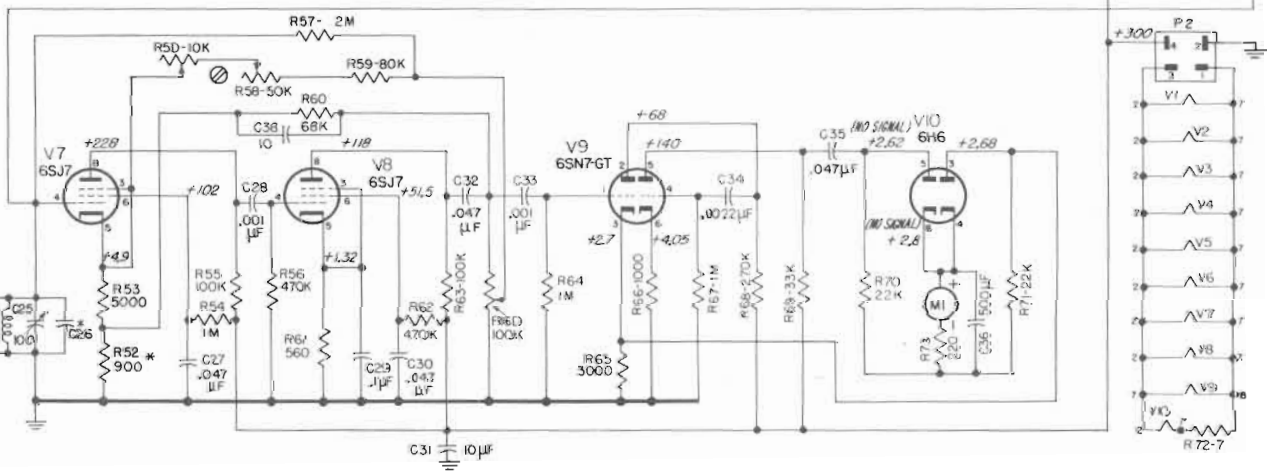
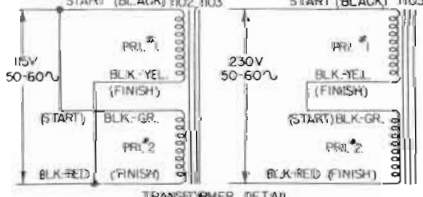

HP MODEL 300A

SELECTIVE AMPLIFIER & METER CIRCUITS

(TOP DECK)
SERIAL 1330 & ABOVE

FIG. 3

THIS CIRCUIT IS INDICATEDLY CORRECT, BUT SMALL DIFFERENCES MAY EXIST FOR ANY PARTICULAR INSTRUMENT. COMPARISON AND CROSS-CHECKING WILL ENABLE IDENTIFICATION OF NECESSARY PARTS.

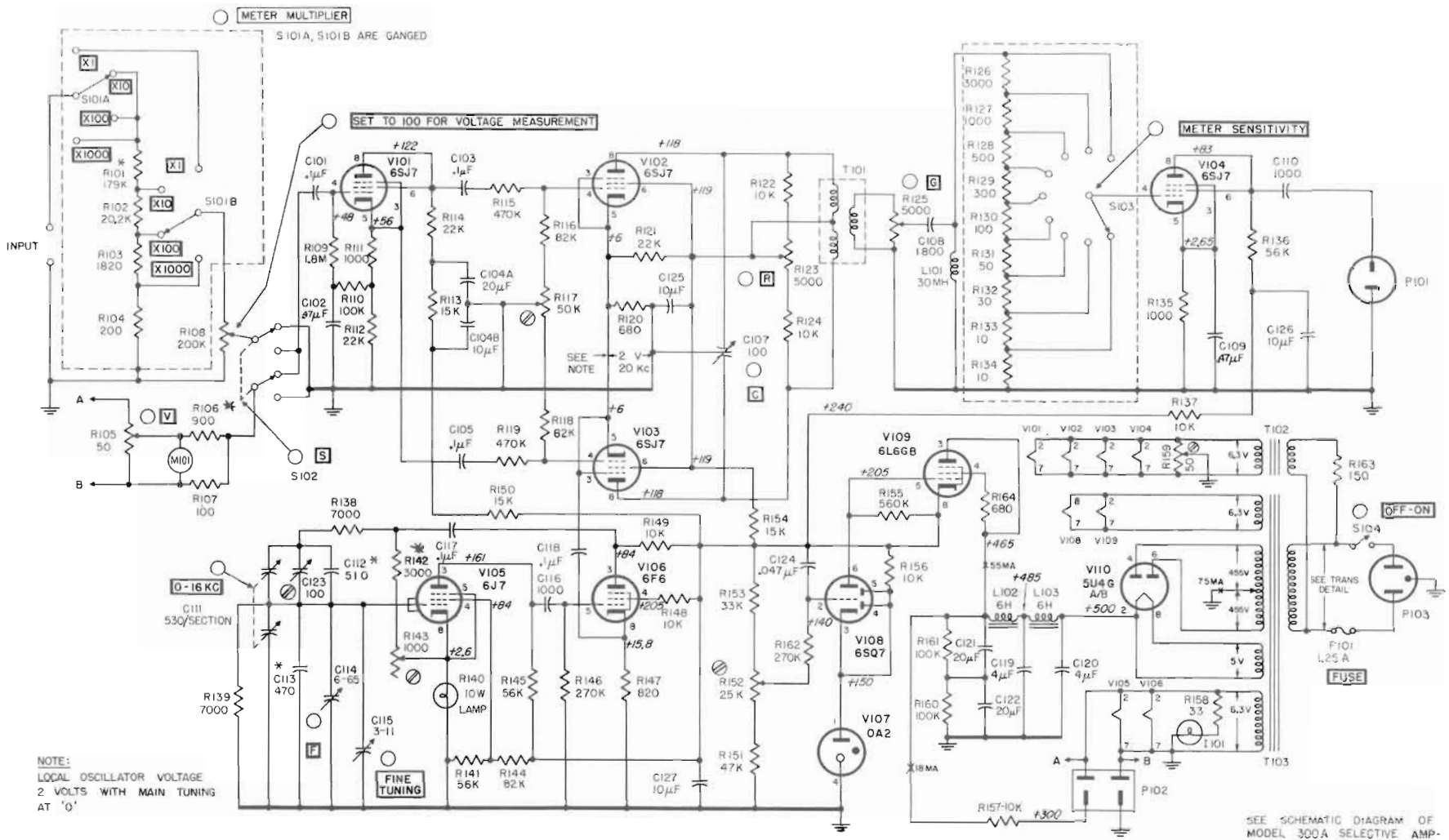

hp MODEL 300A
MODULATOR, OSCILLATOR & POWER SUPPLY
 (BOTTOM DECK)
 SERIAL 1610 & ABOVE
 FIG. 4

THIS CIRCUIT IS BASICALLY CORRECT, BUT SMALL DIFFERENCES MAY EXIST FOR ANY PARTICULAR INSTRUMENT. COMPARISON AND CROSS-CHECKING WILL ENABLE IDENTIFICATION OF NECESSARY PARTS.

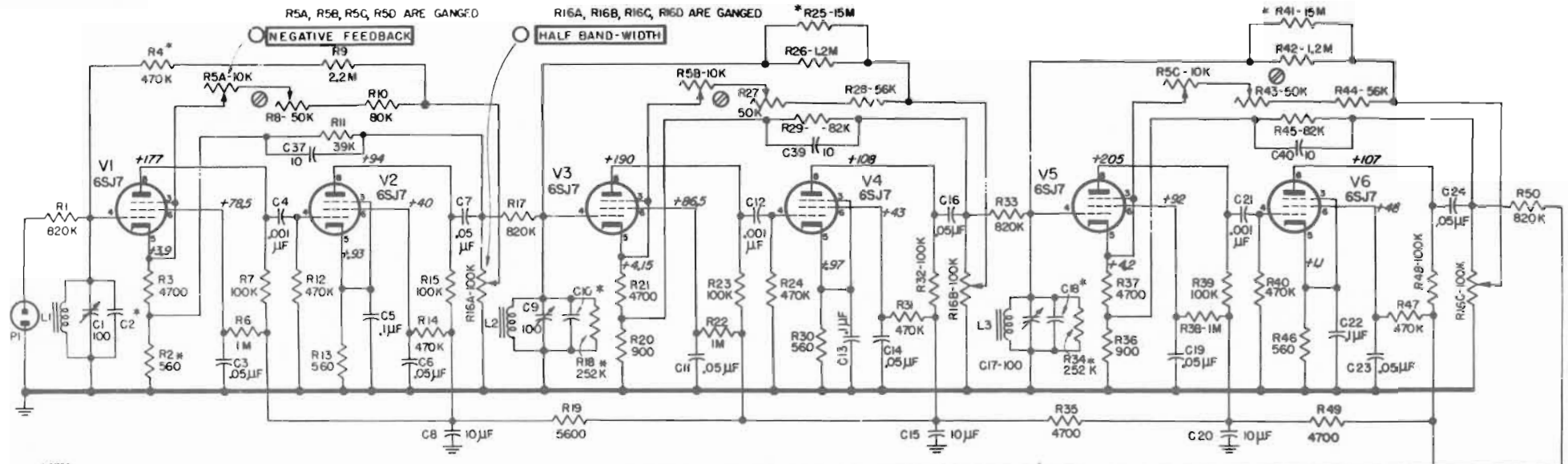

NOTES:
(THESE NOTES ALSO APPLY TO THE SCHEMATIC OF MODEL 300A MODULATOR, OSCILLATOR, & POWER SUPPLY SECTIONS.)

CONDITIONS OF DC VOLTAGE MEASUREMENT:

1. 115/230V, 60~ POWER SUPPLY
2. MEASURED BETWEEN INDICATED POINTS & CHASSIS WITH A VOLTMETER OF 122 MEGOHMS INPUT RESISTANCE.
3. PANEL CONTROLS SET AT ANY POSITION

- PANEL CONTROL
- ⊗ SCREWDRIVER CONTROL

⊥ CHASSIS

CAPACITANCE VALUES GIVEN IN μF UNLESS OTHERWISE NOTED.

K=1000 OHMS

M=100 OHMS

* ELECTRICAL VALUE ADJUSTED AT THE FACTORY; AVERAGE VALUE SHOWN. PART MAY BE OMITTED.

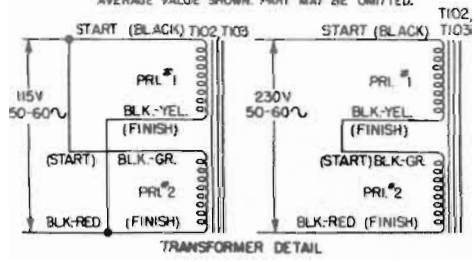

TRANSFORMER DETAIL

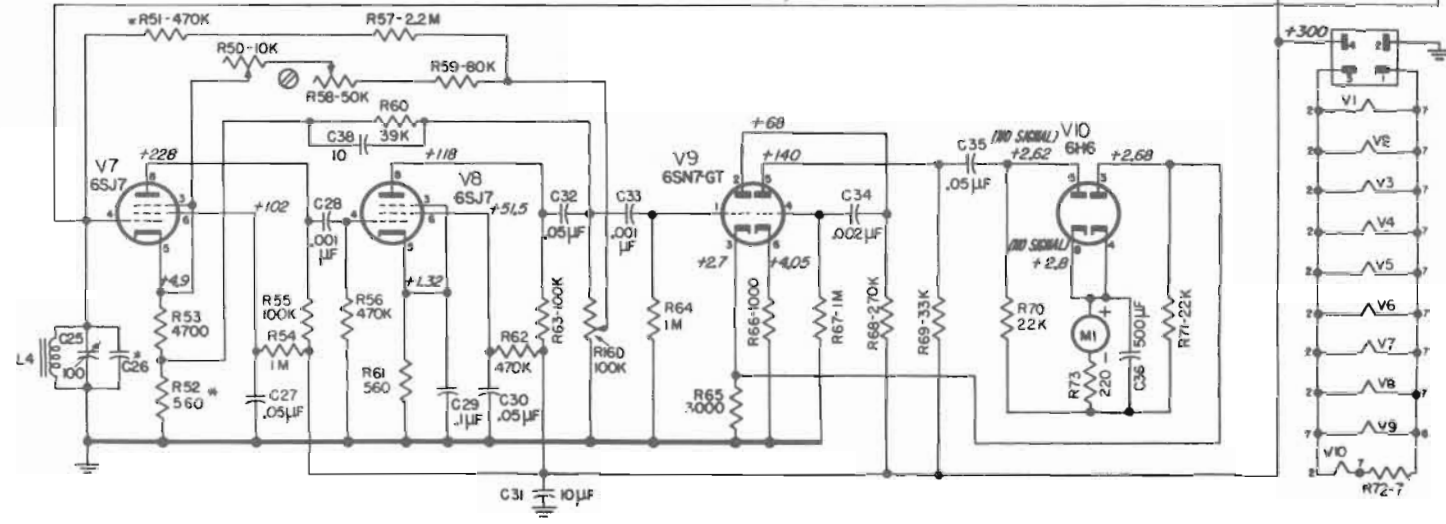

THIS CIRCUIT IS BASICALLY CORRECT, BUT SMALL DIFFERENCES MAY EXIST FOR ANY PARTICULAR INSTRUMENT. COMPARISON AND CROSS-CHECKING WILL ENABLE IDENTIFICATION OF NECESSARY PARTS.

TYPICAL
hp MODEL 300A
SELECTIVE AMPLIFIER & METER CIRCUITS

(TOP DECK)
SERIAL 1329 & BELOW

FIG. 5

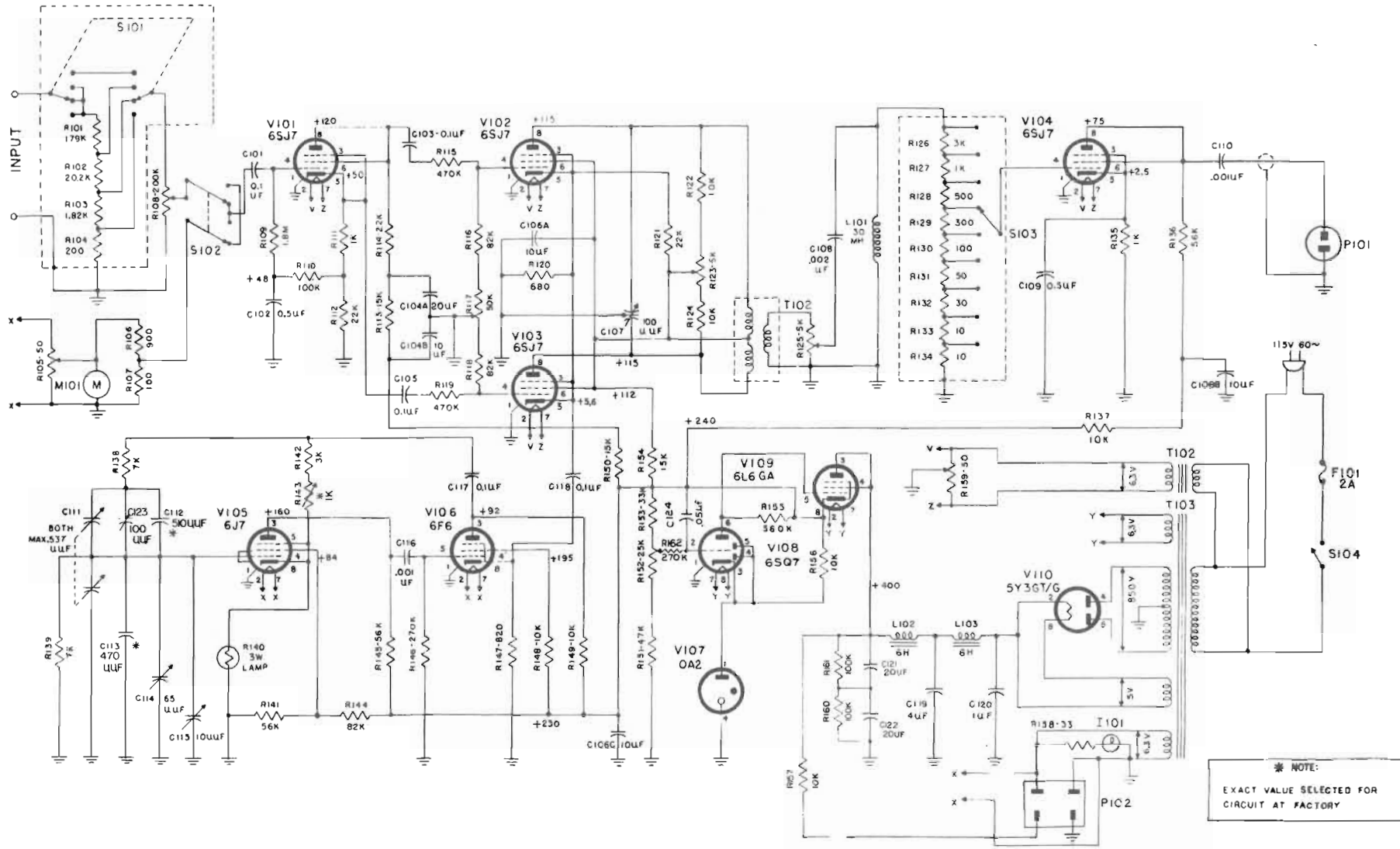

TYPICAL
MODEL 300A
MODULATOR, OSCILLATOR & POWER SUPPLY
 (BOTTOM DECK)
 SERIAL 1609 & BELOW

FIG. 6

THIS CIRCUIT IS BASICALLY CORRECT, BUT SMALL DIFFERENCES MAY EXIST FOR ANY PARTICULAR INSTRUMENT. COMPARISON AND CROSS-CHECKING WILL ENABLE IDENTIFICATION OF NECESSARY PARTS.

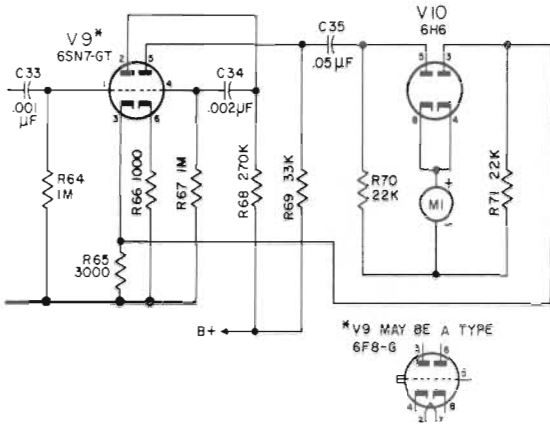

Fig. 7A. Early Amplifier & Meter Circuits

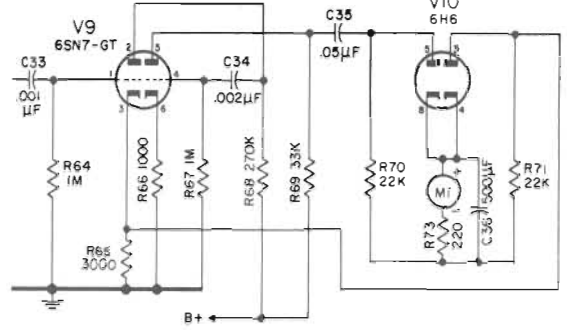

Fig. 7B. Late Amplifier & Meter Circuits

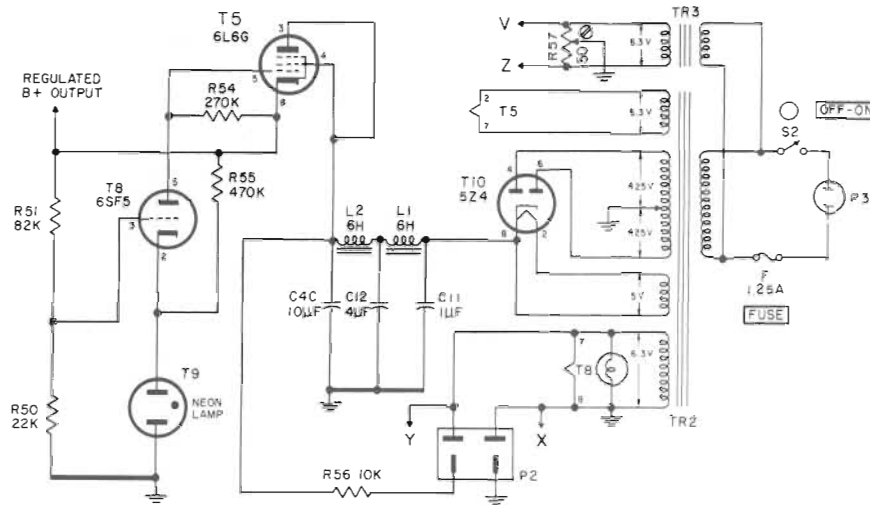

Fig. 7C. One of Earliest Power Supplies. Series Regulator Tube T5 May Be a Type 2A3.

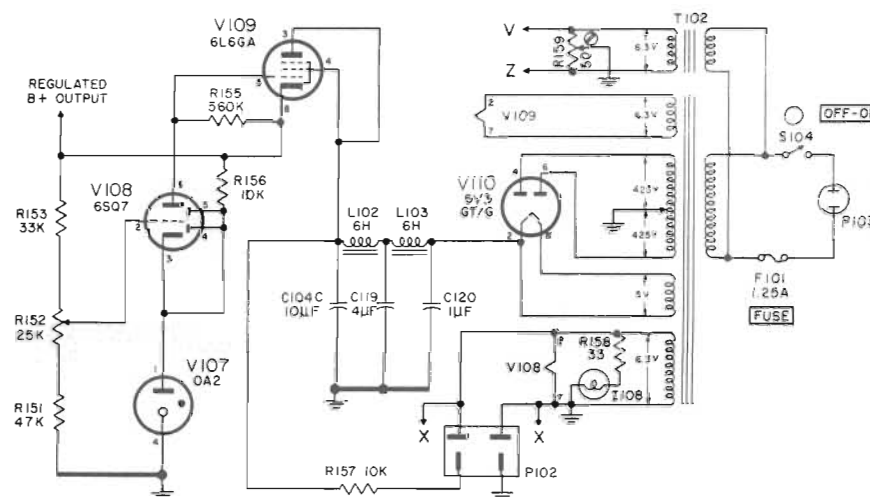

Fig. 7D. Later Power Supply Circuit. Same Basic Circuit as Fig. 7C With a Change in Tube Complement & Control R157 Added.

300A002 11/30/55

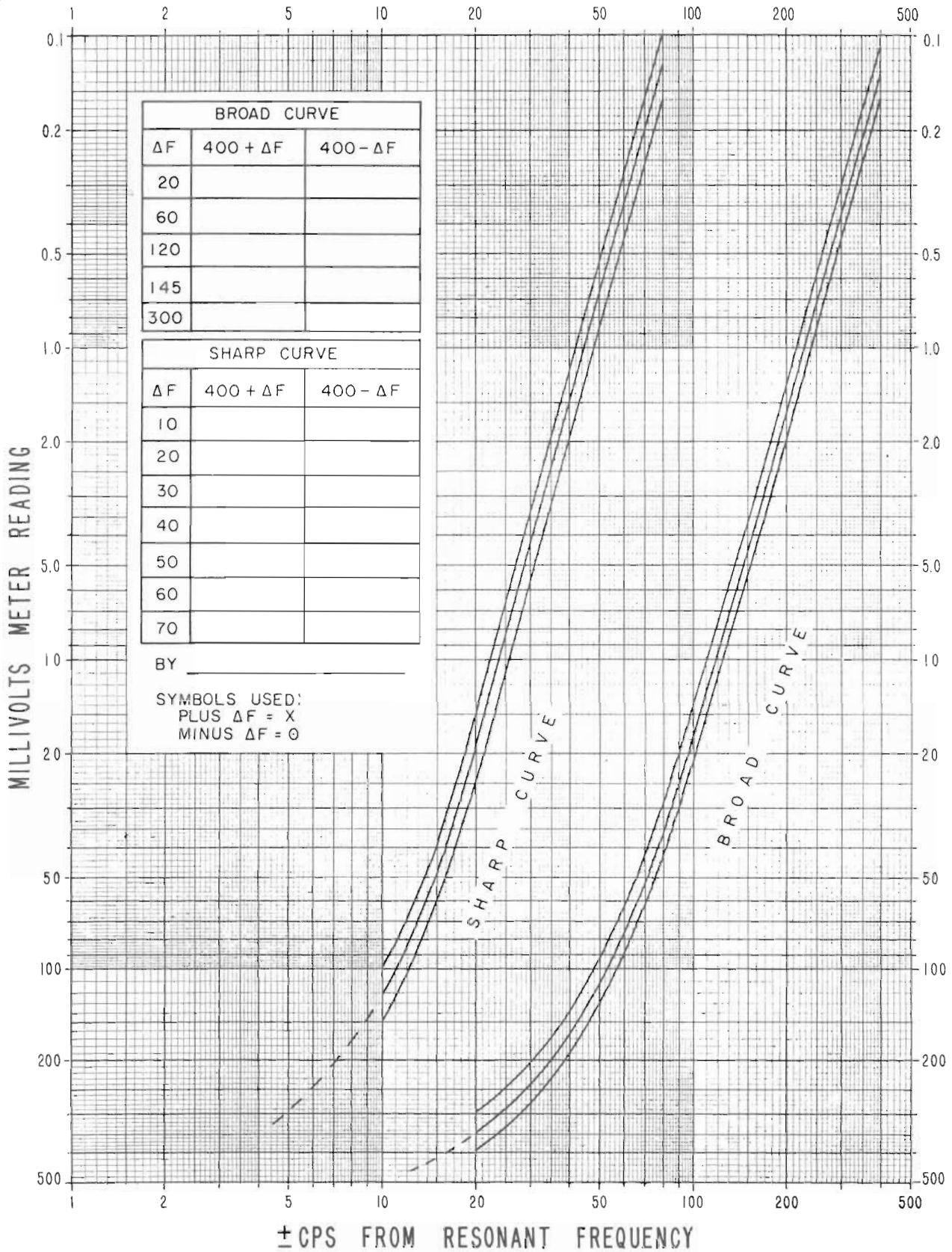

Fig. 8. Chart for Plotting Selectivity Curves

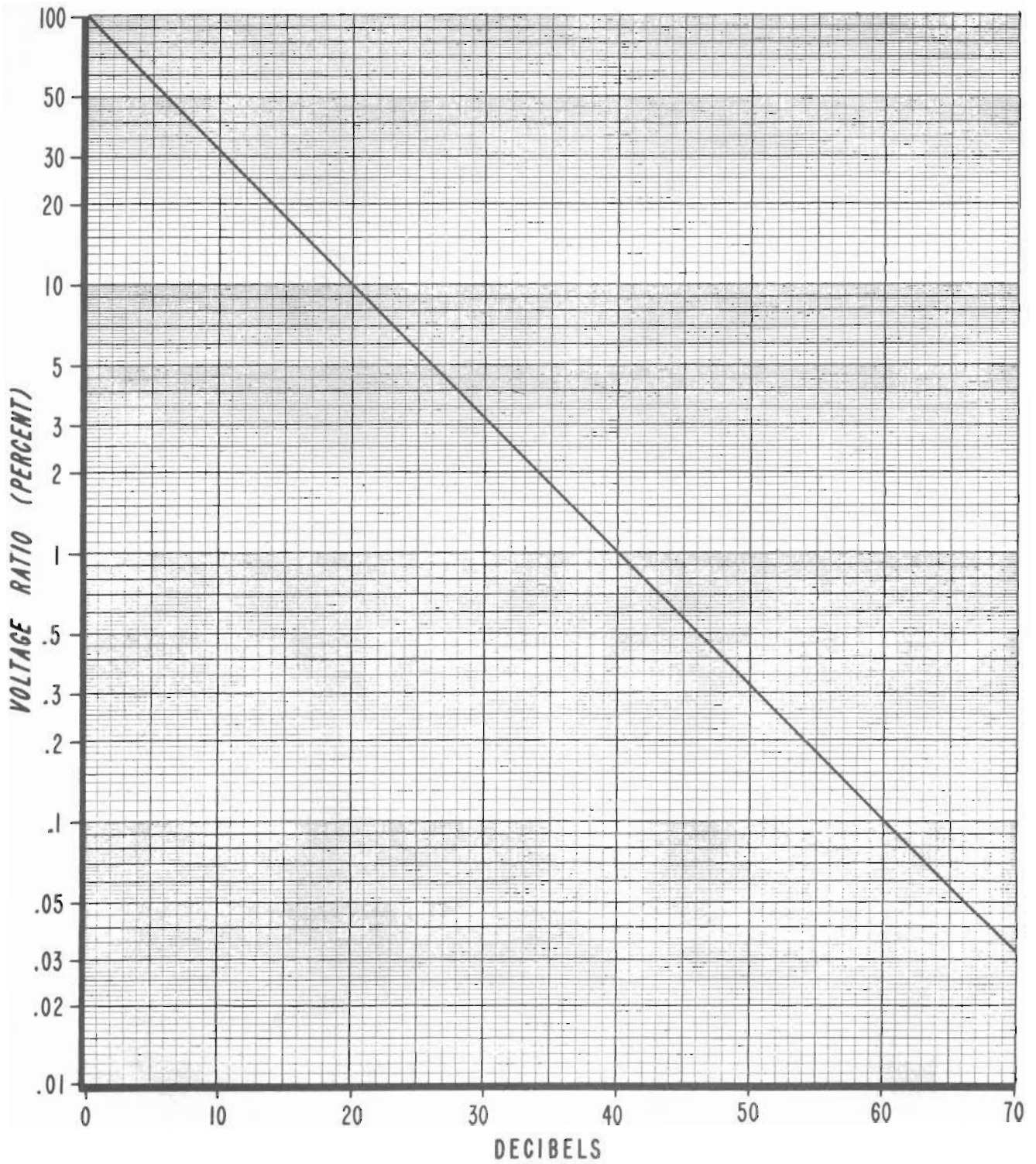

Fig. 9. Graph for Converting Attenuation in Decibels to Voltage Ratio

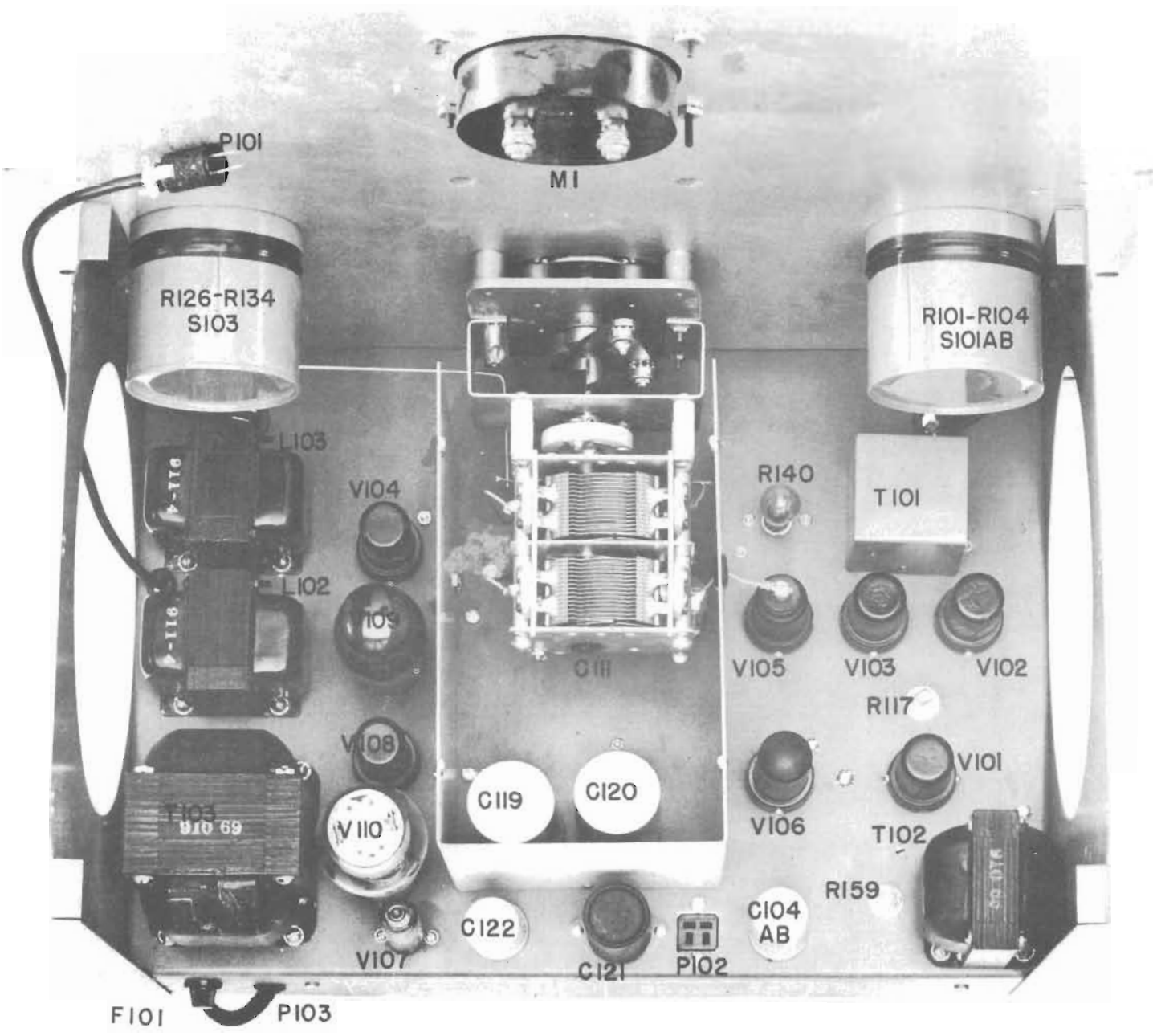

Fig. 10. Top View of Typical Bottom Deck and Back of Control Panel. Top Deck Removed.

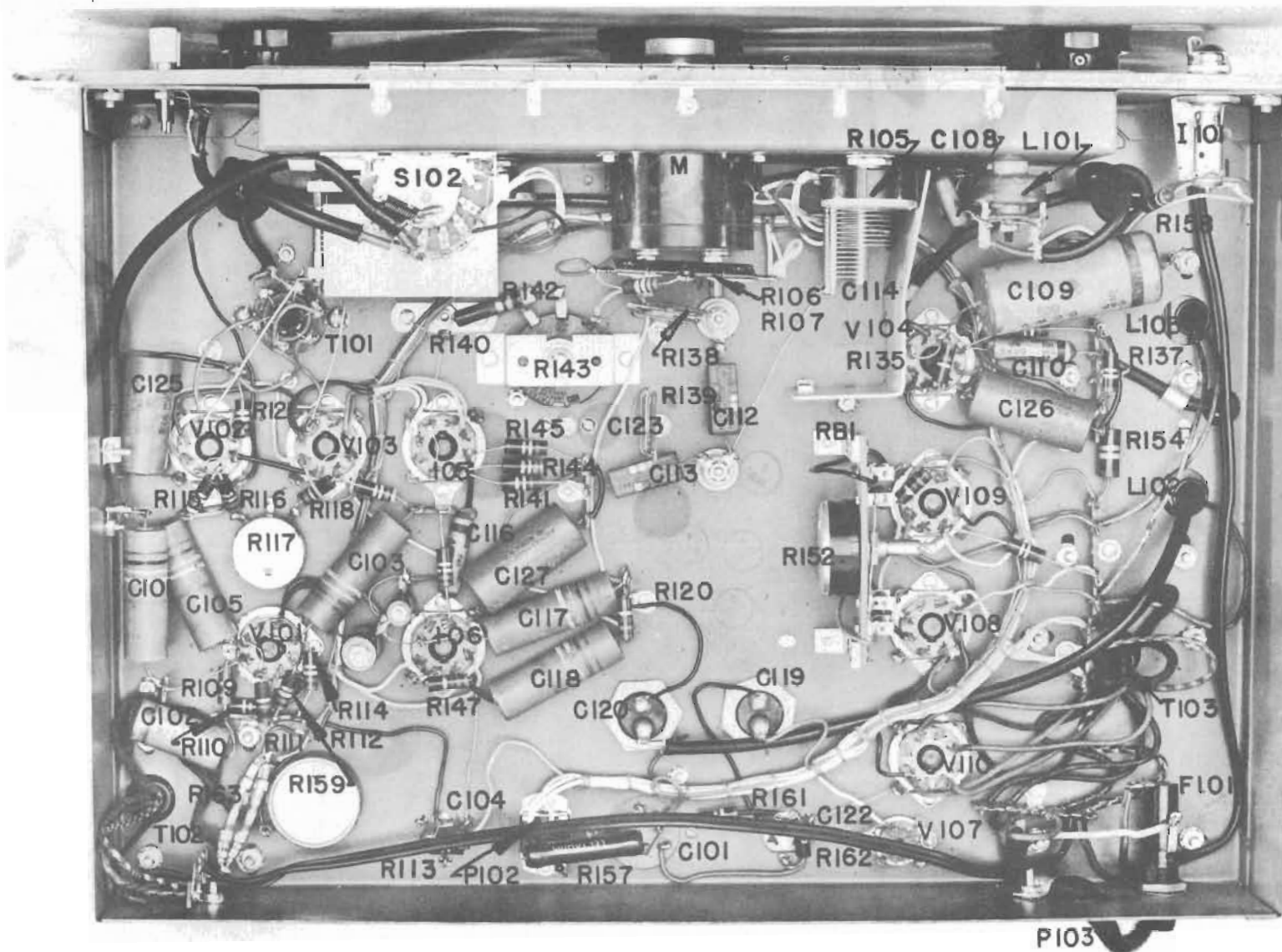

Fig. 11. Bottom View of Typical Bottom Deck

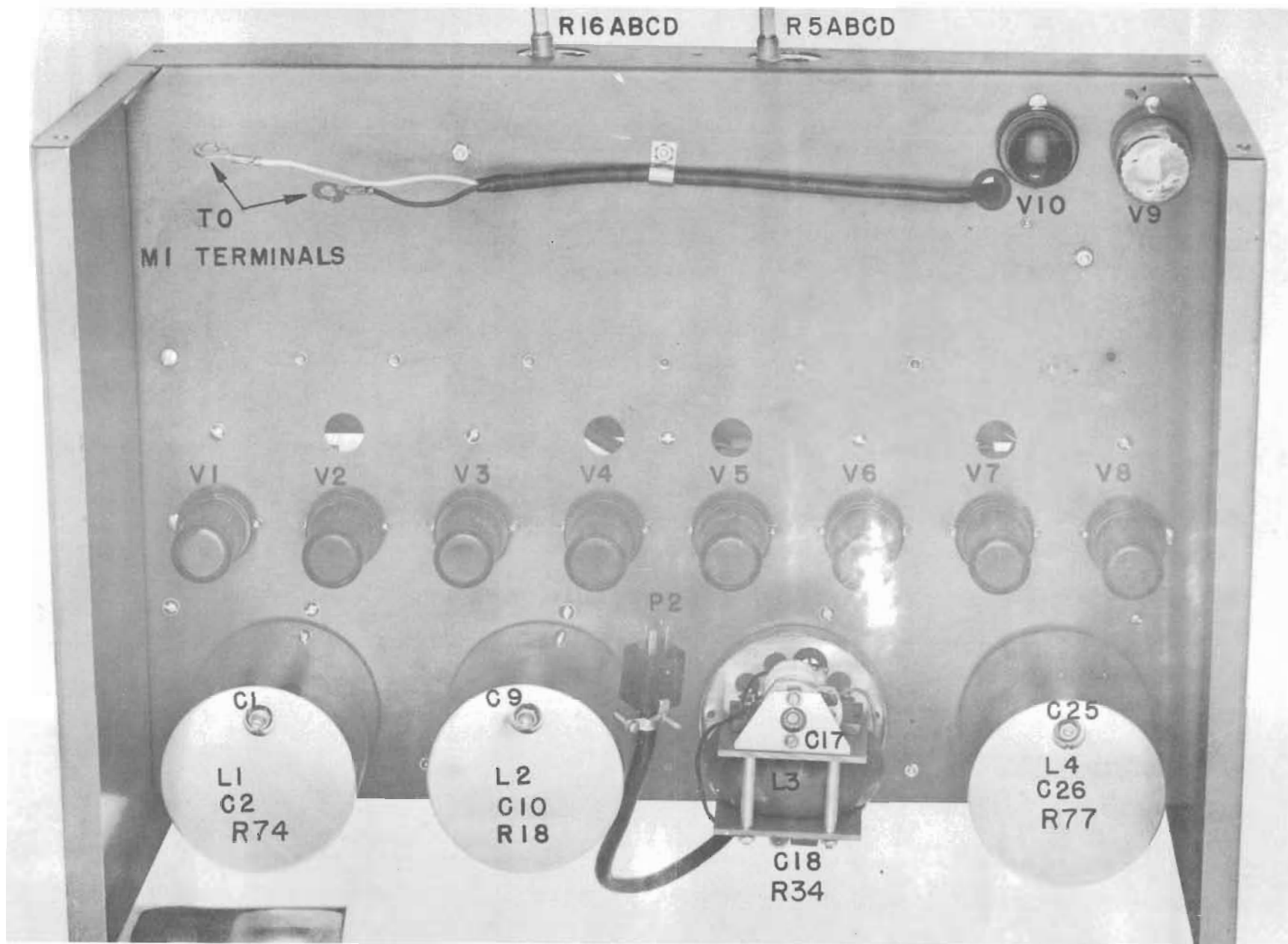

Fig. 12. Top View of Typical Top Deck With Shield Removed to Show Details of Torroid Coil Assembly. Top Deck Separated From Control Panel.

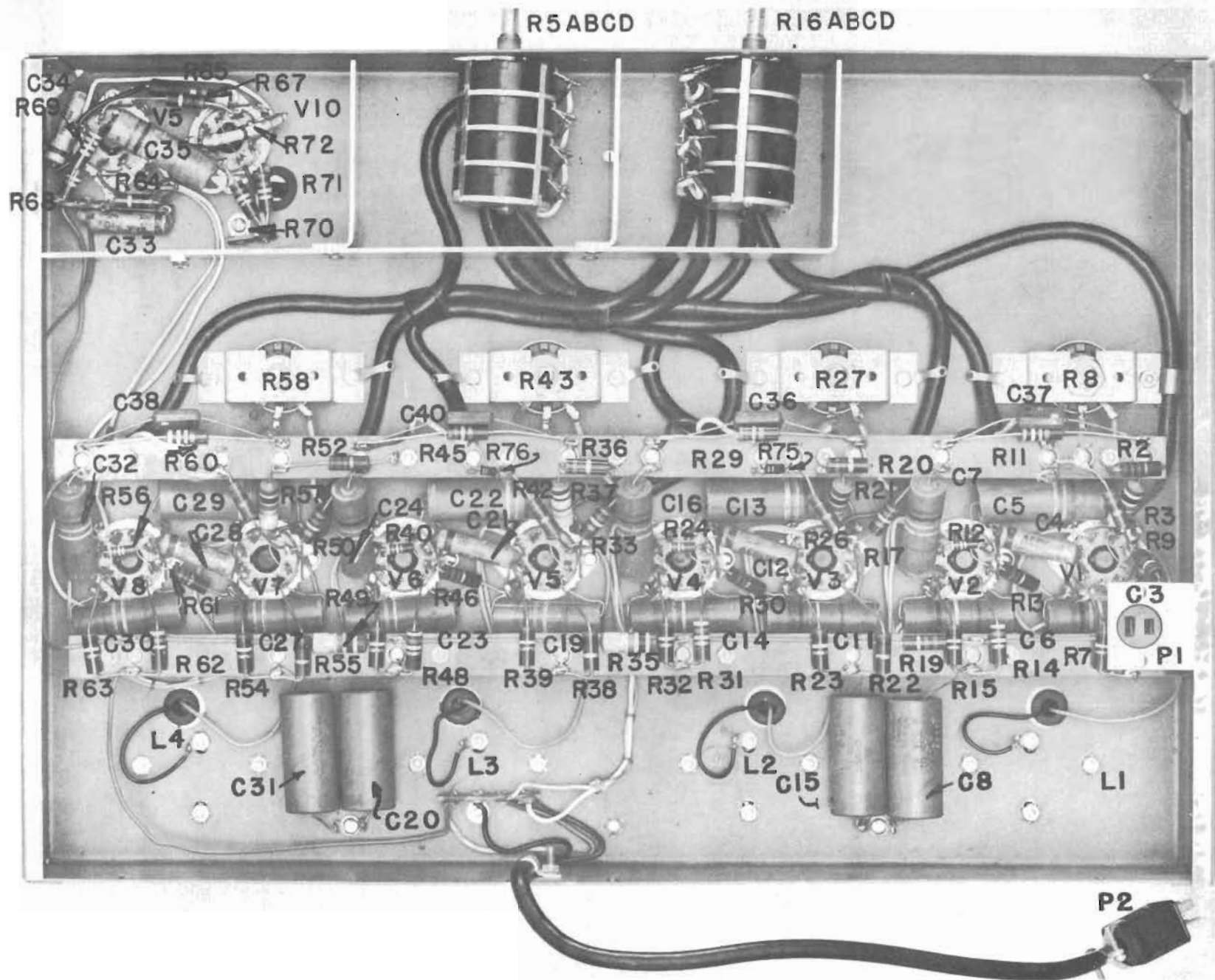

Fig. 13. Bottom View of Typical Top Deck With Control Panel and Bottom Plate Removed

LIST OF CODE LETTERS USED IN TABLE OF REPLACEABLE PARTS TO DESIGNATE THE MANUFACTURERS

CODE LETTER	MANUFACTURER	ADDRESS	CODE LETTER	MANUFACTURER	ADDRESS
A	Aerovox Corp.	New Bedford, Mass.	AK	Hammerlund Mfg. Co., Inc.	New York 1, N. Y.
B	Allen-Bradley Co.	Milwaukee 4, Wis.	AL	Industrial Condenser Corp.	Chicago 18, Ill.
C	Amperite Co.	New York, N. Y.	AM	Insuline Corp. of America	Manchester, N. H.
D	Arrow, Hart & Hegeman	Hartford, Conn.	AN	Jennings Radio Mfg. Corp.	San Jose, Calif.
E	Bussman Manufacturing Co.	St. Louis, Mo.	AO	E. F. Johnson Co.	Waseca, Minn.
F	Carborundum Co.	Niagara Falls, N. Y.	AP	Lenz Electric Mfg. Co.	Chicago 47, Ill.
G	Centralab	Milwaukee 1, Wis.	AQ	Micro-Switch	Freeport, Ill.
H	Cinch-Jones Mfg. Co.	Chicago 24, Ill.	AR	Mechanical Industries Prod. Co.	Akron 8, Ohio
HP	Hewlett-Packard Co.	Palo Alto, Calif.	AS	Model Eng. & Mfg., Inc.	Huntington, Ind.
I	Clarostat Mfg. Co.	Dover, N. H.	AT	The Muter Co.	Chicago 5, Ill.
J	Cornell Dubilier Elec. Co.	South Plainfield, N. J.	AU	Ohmite Mfg. Co.	Skokie, Ill.
K	Hi-Q Division of Aerovox	Olean, N. Y.	AV	Resistance Products Co.	Harrisburg, Pa.
L	Erie Resistor Corp.	Erie 6, Pa.	AW	Radio Condenser Co.	Camden 3, N. J.
M	Fed. Telephone & Radio Corp.	Clifton, N. J.	AX	Shallcross Manufacturing Co.	Collingsdale, Pa.
N	General Electric Co.	Schenectady 5, N. Y.	AY	Solar Manufacturing Co.	Los Angeles 58, Calif.
O	General Electric Supply Corp.	San Francisco, Calif.	AZ	Snaelectro Corp.	New Rochelle, N. Y.
P	Girard-Hopkins	Oakland, Calif.	BA	Spencer Thermostat	Attleboro, Mass.
Q	Industrial Products Co.	Danbury, Conn.	BC	Stevens Manufacturing Co.	Mansfield, Ohio
R	International Resistance Co.	Philadelphia 8, Pa.	BD	Torrington Manufacturing Co.	Van Nuys, Calif.
S	Lectrohm Inc.	Chicago 20, Ill.	BE	Vector Electronic Co.	Los Angeles 65, Calif.
T	Littlefuse Inc.	Des Plaines, Ill.	BF	Weston Electrical Inst. Corp.	Newark 5, N. J.
U	Maguire Industries Inc.	Greenwich, Conn.	BG	Advance Electric & Relay Co.	Burbank, Calif.
V	Micamold Radio Corp.	Brooklyn 37, N. Y.	BH	E. J. DuPont	San Francisco, Calif.
W	Oak Manufacturing Co.	Chicago 10, Ill.	BI	Electronics Tube Corp.	Philadelphia 18, Pa.
X	P. R. Mallory Co., Inc.	Indianapolis, Ind.	BJ	Aircraft Radio Corp.	Boonton, N. J.
Y	Radio Corp. of America	Harrison, N. J.	BK	Allied Control Co., Inc.	New York 21, N. Y.
Z	Sangamo Electric Co.	Marion, Ill.	BL	Augat Brothers, Inc.	Attleboro, Mass.
AA	Sarkis Tarzian	Bloomington, Ind.	BM	Carter Radio Division	Chicago, Ill.
BB	Signal Indicator Co.	Brooklyn 37, N. Y.	BN	CBS Hytron Radio & Electric	Danvers, Mass.
CC	Sprague Electric Co.	North Adams, Mass.	BO	Chicago Telephone Supply	Elkhart, Ind.
DD	Stackpole Carbon Co.	St. Marys, Pa.	BP	Henry L. Crowley Co., Inc.	West Orange, N. J.
EE	Sylvania Electric Products Co.	Warren, Pa.	BQ	Curtiss-Wright Corp.	Carlstadt, N. J.
FF	Western Electric Co.	New York 5, N. Y.	BR	Allen B. DuMont Labs	Clifton, N. J.
GG	Wilkor Products, Inc.	Cleveland, Ohio	BS	Excel Transformer Co.	Oakland, Calif.
HH	Amphenol	Chicago 50, Ill.	BT	General Radio Co.	Cambridge 39, Mass.
II	Dial Light Co. of America	Brooklyn 37, N. Y.	BU	Hughes Aircraft Co.	Culver City, Calif.
JJ	Leecraft Manufacturing Co.	New York, N. Y.	BV	International Rectifier Corp.	El Segundo, Calif.
KK	Switchcraft, Inc.	Chicago 22, Ill.	BW	James Knights Co.	Sandwich, Ill.
LL	Gremar Manufacturing Co.	Wakefield, Mass.	BX	Mueller Electric Co.	Cleveland, Ohio
MM	Carad Corp.	Redwood City, Calif.	BY	Precision Thermometer & Inst. Co.	Philadelphia 30, Pa.
NN	Electra Manufacturing Co.	Kansas City, Mo.	BZ	Radio Essentials Inc.	Mt. Vernon, N. Y.
OO	Acro Manufacturing Co.	Columbus 16, Ohio	CA	Raytheon Manufacturing Co.	Newton, Mass.
PP	Alliance Manufacturing Co.	Alliance, Ohio	CB	Tung-Sol Lamp Works, Inc.	Newark 4, N. J.
QQ	Arco Electronics, Inc.	New York 13, N. Y.	CD	Varian Associates	Palo Alto, Calif.
RR	Astron Corp.	East Newark, N. J.	CE	Victory Engineering Corp.	Union, N. J.
SS	Axel Brothers Inc.	Long Island City, N. Y.	CF	Weckesser Co.	Chicago 30, Ill.
TT	Belden Manufacturing Co.	Chicago 44, Ill.	CG	Wilco Corporation	Indianapolis, Ind.
UU	Bird Electronics Corp.	Cleveland 14, Ohio	CH	Winchester Electronics, Inc.	Santa Monica, Calif.
VV	Barber Colman Co.	Rockford, Ill.	CI	Malco Tool & Die	Los Angeles 42, Calif.
WW	Bud Radio Inc.	Cleveland 3, Ohio	CJ	Oxford Electric Corp.	Chicago 15, Ill.
XX	Allen D. Cardwell Mfg. Co.	Plainville, Conn.	CK	Camloc-Fastener Corp.	Paramus, N. J.
YY	Cinema Engineering Co.	Burbank, Calif.	CL	George K. Garrett	Philadelphia 34, Pa.
ZZ	Any brand tube meeting RETMA standards.		CM	Union Switch & Signal	Swissvale, Pa.
AB	Corning Glass Works	Corning, N. Y.	CN	Radio Receptor	New York 11, N. Y.
AC	Dale Products, Inc.	Columbus, Neb.	CO	Automatic & Precision Mfg. Co.	Yonkers, N. Y.
AD	The Drake Mfg. Co.	Chicago 22, Ill.	CP	Bassick Co.	Bridgeport 2, Conn.
AE	Elco Corp.	Philadelphia 24, Pa.	CQ	Birnbach Radio Co.	New York 13, N. Y.
AF	Hugh H. Eby Co.	Philadelphia 44, Pa.	CR	Fischer Specialties	Cincinnati 6, Ohio
AG	Thomas A. Edison, Inc.	West Orange, N. J.	CS	Telefunken (c/o MVM, Inc.)	New York, N. Y.
AH	Fansteel Metallurgical Corp.	North Chicago, Ill.	CT	Potter-Brumfield Co.	Princeton, Ind.
AI	General Ceramics & Steatite Corp.	Keasbey, N. J.	CU	Cannon Electric Co.	Los Angeles, Calif.
AJ	The Gudeman Co.	Sunnyvale, Calif.	CV	Dynac, Inc.	Palo Alto, Calif.
			CW	Good-All Electric Mfg. Co.	Ogallala, Nebr.

TABLE OF REPLACEABLE PARTS

GENERAL -

The following parts list may be used to determine replacement parts for all -hp- Model 300A Harmonic Wave Analyzers. To determine the required replacement part, refer to the schematic diagrams given in Fig. 3 and Fig. 4. Use the circuit reference obtained from the schematic diagrams to identify correct component in the Table of Replaceable Parts.

To assure receiving the correct replacement part, be sure to include instrument Model and Serial numbers as well as the -hp- Stock Number and Description of the desired part. Failure to include this information may result in delay due to a wrong part being received or additional correspondence being required before proper part identification is possible.

The Model 300A has been manufactured over a span of several years with no major change in specifications or in basic circuitry. The components used, however, have changed. Different tube type, improved toroid coils, and other miscellaneous components of higher quality have been incorporated whenever they became available. The components given in this parts list are those used in the latest instruments.

Some older instruments must be completely modernized before these new parts can be used. Refer to the TUBE COMPLEMENT & TUBE REPLACEMENTS, CIRCUIT DESCRIPTION, and CIRCUIT MODIFICATIONS sections of this manual. Factory modernization is recommended for older instruments not covered under CIRCUIT MODIFICATIONS. Field modernization of these older instruments is not practical.

It is necessary in some instances to substitute parts in this instrument. These substitutions do not impair instrument performance. Either the substitute part or the part specified in the Replaceable Parts Table may be used for replacement purposes.

TABLE OF REPLACEABLE PARTS

CIRCUIT REF.	DESCRIPTION, MFR. * & MFR. DESIGNATION	Ⓢ STOCK NO.	#			
	<u>TOP DECK</u>					
C1	Capacitor: variable, air dielectric, 100 μf , (part of Toroid Coil Assembly) All Star	12-11	5			
C2	Capacitor: Value selected at factory.		4			
C3	Capacitor: fixed, paper dielectric .047 μf , $\pm 10\%$, 600 vdcw, 125°C CC*	16-15	14			
C4	Capacitor: fixed, paper dielectric, .001 μf , $\pm 10\%$, 600 vdcw, 125°C CC*	16-21	7			
C5	Capacitor: fixed, paper dielectric, 0.1 μf , $\pm 10\%$, 600 vdcw, 125°C CC*	16-1	9			
C6, 7	Same as C3					
C8	Capacitor: fixed, electrolytic, 10 μf , $\pm 50\%$, 450 vdcw, 85°C X*	18-10	7			
C9	Same as C1					
C10	Same as C2					

* See "List of Manufacturers Code Letters For Replaceable Parts Table".

Total quantity used in the instrument.

TABLE OF REPLACEABLE PARTS

CIRCUIT REF.	DESCRIPTION, MFR. * & MFR. DESIGNATION	Ⓢ STOCK NO.	#				
TOP DECK (CONTINUED)							
C11	Same as C3						
C12	Same as C4						
C13	Same as C5						
C14	Same as C3						
C15	Same as C8						
C16	Same as C3						
C17	Same as C1						
C18	Same as C2						
C19	Same as C3						
C20	Same as C8						
C21	Same as C4						
C22	Same as C5						
C23, 24	Same as C3						
C25	Same as C1						
C26	Same as C2						
C27	Same as C3						
C28	Same as C4						
C29	Same as C5						
C30	Same as C3						
C31	Same as C8						
C32	Same as C3						
C33	Same as C4						
C34	Capacitor: fixed, paper dielectric, .0022 μ f, $\pm 10\%$, 600 vdcw, 125°C CC*	16-22	1				
C35	Same as C3						
C36	Capacitor: fixed, electrolytic, 500 μ f, 15 vdcw, 85°C X*	18-5	1				

* See "List of Manufacturers Code Letters For Replaceable Parts Table".

Total quantity used in the instrument.

TABLE OF REPLACEABLE PARTS

CIRCUIT REF.	DESCRIPTION, MFR. * & MFR. DESIGNATION	STOCK NO.	#			
	TOP DECK (CONTINUED)					
C37, 38, 39, 40	Capacitor: fixed, mica, 10 $\mu\mu\text{f}$, $\pm 10\%$, 500 vdcw	V*	14-10	4		
J1	Connector, female: 2 contact	H*	125-14	1		
L1, 2, 3, 4	Coil, part of Toroid Coil Assembly (not separately replaceable)					
M1	Meter, indicating: 1 ma movement		112-4	1		
P1	This circuit reference not assigned					
P2	Connector, male: 4 contact, cable type	H*	125-10	1		
R1	Resistor: fixed, deposited carbon, 830,000 ohms, $\pm 1\%$, 1 W	NN*	31-830K	8		
R2	Resistor: fixed, deposited carbon, 900 ohms, $\pm 1\%$, 1 W Electrical value adjusted at factory.	NN*	31-900	4		
R3	Resistor: fixed, deposited carbon, 5000 ohms, $\pm 1\%$, 1 W	NN*	31-5000	4		
R4	This circuit reference deleted in later instruments					
R5	Resistor: variable, composition, linear taper, 4 sections, 10,000 ohms/sect.	G*	210-23	1		
R6	Resistor: fixed, composition, 1 megohm, $\pm 10\%$, 1 W	B*	24-1M	6		
R7	Resistor: fixed, composition, 100,000 ohms, $\pm 10\%$, 1 W	B*	24-100K	11		
R8	Resistor: variable, composition, linear taper, 50,000 ohms	I*	210-18	5		
R9	Resistor: fixed, deposited carbon, 2 megohms, $\pm 1\%$, 1 W	NN*	31-2M	2		
R10	Resistor: fixed, deposited carbon, 80,000 ohms, $\pm 1\%$, 1 W	NN*	31-80K	2		
R11	Resistor: fixed, composition, 68,000 ohms, $\pm 10\%$, 1 W	B*	24-68K	4		
R12	Resistor: fixed, composition, 470,000 ohms, $\pm 10\%$, 1/2 W	B*	23-470K	4		

* See "List of Manufacturers Code Letters For Replaceable Parts Table".
Total quantity used in the instrument.

TABLE OF REPLACEABLE PARTS

CIRCUIT REF.	DESCRIPTION, MFR. * & MFR. DESIGNATION	Ⓢ STOCK NO.	#			
TOP DECK (CONTINUED)						
R13	Resistor: fixed, composition, 560 ohms, $\pm 10\%$, 1 W	B*	24-560	4		
R14	Resistor: fixed, composition, 470,000 ohms, $\pm 10\%$, 1 W	B*	24-470K	6		
R15	Same as R7					
R16	Resistor: variable, composition, 4 sections, 100,000 ohms/sect.	G*	210-24	1		
R17	Same as R1					
R18	Resistor: fixed, deposited carbon, 479,000 ohms, $\pm 1\%$, 1 W Electrical value adjusted at factory	NN*	31-479K	4		
R19	Resistor: fixed, composition, 5600 ohms, $\pm 10\%$, 1 W		24-5600	1		
R20	Same as R2					
R21	Same as R3					
R22	Same as R6					
R23	Same as R7					
R24	Same as R12					
R25	This circuit reference deleted in later instruments					
R26	Resistor: fixed, deposited carbon, 1.63 megohms, $\pm 1\%$, 1 W	NN*	31-1.63M	2		
R27	Same as R8					
R28	Resistor: fixed, deposited carbon, 56,000 ohms, $\pm 1\%$, 1 W	NN*	31-56K	2		
R29	Same as R11					
R30	Same as R13					
R31	Same as R14					
R32	Same as R7					
R33	Same as R1					
R34	Same as R18					

* See "List of Manufacturers Code Letters For Replaceable Parts Table".

Total quantity used in the instrument.

TABLE OF REPLACEABLE PARTS

CIRCUIT REF.	DESCRIPTION, MFR. * & MFR. DESIGNATION	Ⓜ STOCK NO.	#			
TOP DECK (CONTINUED)						
R35	Resistor: fixed, composition, 4700 ohms, $\pm 10\%$, 1 W	24-4700	2			
R36	Same as R2					
R37	Same as R3					
R38	Same as R6					
R39	Same as R7					
R40	Same as R12					
R41	This circuit reference deleted in later instruments					
R42	Same as R26					
R43	Same as R8					
R44	Same as R28					
R45	Same as R11					
R46	Same as R13					
R47	Same as R14					
R48	Same as R7					
R49	Same as R35					
R50	Same as R1					
R51	This circuit reference deleted in later instruments					
R52	Same as R2					
R53	Same as R3					
R54	Same as R6					
R55	Same as R7					
R56	Same as R12					
R57	Same as R9					
R58	Same as R8					
R59	Same as R10					

* See "List of Manufacturers Code Letters For Replaceable Parts Table".

Total quantity used in the instrument.

TABLE OF REPLACEABLE PARTS

CIRCUIT REF.	DESCRIPTION, MFR. * & MFR. DESIGNATION	Ⓢ STOCK NO.	#			
	TOP DECK (CONTINUED)					
R60	Same as R11					
R61	Same as R13					
R62	Same as R14					
R63	Same as R7					
R64	Same as R6					
R65	Resistor: fixed, wirewound, 3000 ohms, $\pm 5\%$, 1 W	R*	26-3000	2		
R66	Resistor: fixed, composition, 1000 ohms, $\pm 10\%$, 1 W	B*	24-1000	3		
R67	Same as R6					
R68	Resistor: fixed, composition, 270,000 ohms, $\pm 10\%$, 1 W	B*	24-270K	3		
R69	Resistor: fixed, composition, 33,000 ohms, $\pm 10\%$, 1 W	B*	24-33K	1		
R70, 71	Resistor: fixed, composition, 22,000 ohms, $\pm 10\%$, 1 W	B*	24-22K	4		
R72	Resistor: fixed, wirewound, 7 ohms, $\pm 10\%$, 2 W	I*	26-18	1		
R73	Resistor: fixed, composition 220 ohms, $\pm 10\%$, 1 W	B*	24-220	1		
R74	Same as R18					
R75, 76	Resistor: fixed, composition, 150,000 ohms, $\pm 10\%$, 1/2 W Electrical value adjusted at factory	B*	23-150K	2		
R77	Same as R18					
R78, 79, 80, 81	Same as R1 Electrical value adjusted at factory					
V1 thru V8	Tube, electron: 6SJ7	ZZ*	212-6SJ7	12		

* See "List of Manufacturers Code Letters For Replaceable Parts Table".

Total quantity used in the instrument.

TABLE OF REPLACEABLE PARTS

CIRCUIT REF.	DESCRIPTION, MFR. * & MFR. DESIGNATION	STOCK NO.	#				
TOP DECK (CONTINUED)							
V9	Tube, electron: 6SN7GT or 6F8G (replace with same type as found in instrument. See TUBE COM- PLEMENT & TUBE REPLACE- MENTS section.)	212-6SN7GT or 212-6F8G	1				
	ZZ*						
V10	Tube, electron: 6H6	212-6H6	1				
	ZZ*						
MISCELLANEOUS							
	Toroid Coil Assembly: includes toroid coil, fixed capacitor, resistor, and trimmer capacitor	3A-62	1				
	HP*						
BOTTOM DECK							
C101	Same as C5						
C102	Capacitor: fixed, paper dielectric, .47 μ f, $\pm 10\%$, 200 vdcw	16-37	2				
	CC*						
C103	Same as C5						
C104	Capacitor: fixed, electrolytic, 3 sections, 10 μ f/sect., 450 vdcw	18-31HP	1				
	CC*						
C105	Same as C5						
C106	This circuit reference has been replaced by C125, C126, C127						
C107	Capacitor: variable, air dielectric, 100 μ f	12-13	1				
	XX*						
C108	Capacitor: fixed, mica, 1800 μ f, $\pm 10\%$, 500 vdcw	14-47	1				
	Z*						
C109	Same as C102						
C110	Same as C4						
C111	Capacitor: variable, air dielectric, 2 sections, 530 μ f/sect.	12-2	1				
	AW*						
C112	Capacitor: fixed, silver mica, 510 μ f, $\pm 5\%$, 500 vdcw Electrical value adjusted at factory	15-27	1				
	A*						

* See "List of Manufacturers Code Letters For Replaceable Parts Table".

Total quantity used in the instrument.

TABLE OF REPLACEABLE PARTS

CIRCUIT REF.	DESCRIPTION, MFR. * & MFR. DESIGNATION	Ⓢ STOCK NO.	#			
BOTTOM DECK (CONTINUED)						
C113	Capacitor: fixed, silver mica, .470 $\mu\mu\text{f}$, $\pm 5\%$, 500 vdcw Electrical value adjusted at factory V*	15-90	1			
C114	Capacitor: variable, air dielectric, 6 - 65 $\mu\mu\text{f}$ All Star	12-34	1			
C115	Capacitor: variable, air dielectric, 3 - 11 $\mu\mu\text{f}$ All Star	12-33	1			
C116	Same as C4					
C117, 118	Same as C5					
C119, 120	Capacitor: fixed, paper dielectric, 4 μf , 600 vdcw Z*	17-10	2			
C121, 122	Capacitor: fixed, electrolytic, 20 μf , 450 vdcw CC*	18-20HP	2			
C123	Capacitor: variable, air dielectric, 100 $\mu\mu\text{f}$ All Star	12-11				
C124	Same as C3					
C125, 126, 127	Same as C8					
F101	Fuse: 1.25 amp, "Slo-Blo" T*	211-58	1			
I101	Lamp, incandescent: 6-8V, .15 amp., #47 N*	211-47	1			
L101	Coil, R. F.: 30 mh MM*	48-4	1			
L102, 103	Filter, reactor: 6H @ 125 ma, 240 ohms Paeco	911-4	2			
M101	Meter: 0-10V, "AC calibrate". This meter is used for replacement in all instruments regardless of full scale calibration of original meter. Simpson	112-8	1			
PI01	Connector, male: 2 contact, cable type H*	125-22	1			
PI02	Connector, female: 4 contact, chassis mounting H*	125-11	1			

* See "List of Manufacturers Code Letters For Replaceable Parts Table".

Total quantity used in the instrument.

TABLE OF REPLACEABLE PARTS

CIRCUIT REF.	DESCRIPTION, MFR. * & MFR. DESIGNATION	Ⓟ STOCK NO.	#			
BOTTOM DECK (CONTINUED)						
PI03	Power Cable Elec. Cords	812-56	1			
R101, 102, 103, 104	Resistor: part of Meter Multiplier Switch Assembly					
R105	Resistor: variable, wirewound, linear taper, 50 ohms, $\pm 10\%$ G*	210-2	2			
R106, 107	Resistor: fixed, wirewound, precision, 900 and 100 ohms Electrical value adjusted at factory HP*	3A-26	2			
R108	Resistor: variable, composition, 200,000 ohms, $\pm 10\%$ BO*	210-22	1			
R109	Resistor: fixed, composition, 1.8 megohms, $\pm 10\%$, 1 W B*	24-1.8M	1			
R110	Same as R7					
R111	Same as R66					
R112	Same as R70					
R113	Resistor: fixed, composition, 15,000 ohms, $\pm 10\%$, 1 W B*	24-15K	2			
R114	Same as R70					
R115	Same as R14					
R116	Resistor: fixed, composition, 82,000 ohms, $\pm 10\%$, 1 W B*	24-82K	3			
R117	Same as R8					
R118	Same as R116					
R119	Same as R14					
R120	Resistor: fixed, composition, 680 ohms, $\pm 10\%$, 1 W B*	24-680	2			
R121	Same as R70					
R122	Resistor: fixed, composition, 10,000 ohms, $\pm 10\%$, 1 W B*	24-10K	2			
R123	Resistor: variable, composition, linear taper, 5000 ohms G*	210-15	2			

* See "List of Manufacturers Code Letters For Replaceable Parts Table".

Total quantity used in the instrument.

TABLE OF REPLACEABLE PARTS

CIRCUIT REF.	DESCRIPTION, MFR. * & MFR. DESIGNATION	Ⓜ STOCK NO.	#			
	BOTTOM DECK (CONTINUED)					
R124	Same as R122					
R125	Same as R123					
R126 thru R134	Resistor: part of Meter Sensitivity Switch Assembly					
R135	Same as R66					
R136	Resistor: fixed, composition, 56,000 ohms, $\pm 10\%$, 1 W	B*	24-56K	4		
R137	Same as R122					
R138, 139	Resistor: fixed, wirewound, precision, 7000 ohms	HP*	3A-62A	2		
R140	Lamp: 10 W (see 1 under OTHER LOWER DECK MODIFICATIONS in the CIRCUIT MODIFICATIONS section)	N*	211-29	1		
R141	Same as R136					
R142	Same as R65					
R143	Resistor: variable, wirewound, linear taper, 1000 ohms	G*	210-5	1		
R144	Same as R116					
R145	Same as R136					
R146	Same as R68					
R147	Resistor: fixed, composition, 820 ohms, $\pm 10\%$, 1 W	B*	24-820	1		
R148	Resistor: fixed, wirewound, 10,000 ohms, $\pm 10\%$, 10 W	S*	26-10	2		
R149	Resistor: fixed, wirewound, 10,000 ohms, $\pm 10\%$, 20 W	S*	27-4	1		
R150	Resistor: fixed, composition, 15,000 ohms, $\pm 10\%$, 2 W	B*	25-15K	1		
R151	Same as R136					
R152	Resistor: variable, composition, linear taper, 25,000 ohms	G*	210-11	1		

* See "List of Manufacturers Code Letters For Replaceable Parts Table".

Total quantity used in the instrument.

TABLE OF REPLACEABLE PARTS

CIRCUIT REF.	DESCRIPTION, MFR. * & MFR. DESIGNATION	STOCK NO.	#			
BOTTOM DECK (CONTINUED)						
R153	Resistor: fixed, composition, 27,000 ohms, $\pm 10\%$, 1 W	B*	24-27K	1		
R154	Same as R113					
R155	Resistor: fixed, composition, 560,000 ohms, $\pm 10\%$, 1 W	B*	24-560K	1		
R156	Resistor: fixed, composition, 10,000 ohms, $\pm 10\%$, 2 W	B*	25-10K	1		
R157	Same as R148					
R158	Resistor: fixed, composition, 33 ohms, $\pm 10\%$, 1 W	B*	24-33	1		
R159	Same as R105					
R160, 161	Same as R7					
R162	Same as R68					
R163	Resistor: fixed, composition, 150 ohms, $\pm 10\%$, 2 W	B*	25-150	1		
R164	Same as R120					
SI01	Input Meter Multiplier Range Switch Assembly	HP*	3A-19I	1		
SI02	Calibration Switch Assembly	HP*	3A-19C	1		
	Switch, calibration: DPDT, lever type	G*	310-156	1		
SI03	Meter Sensitivity Switch Assembly	HP*	3A-19M	1		
SI04	Switch, toggle: SPST	D*	310-11	1		
TI01	Transformer, modulation	HP*	3A-61	1		
TI02	Transformer, heater	BS*	910-65	1		
TI03	Transformer, power (power trans- former replacement may require instrument modernization. See CIRCUIT MODIFICATIONS section)	BS*	910-69	1		
V101, 102, 103, 104	Same as V1					

* See "List of Manufacturers Code Letters For Replaceable Parts Table".

Total quantity used in the instrument.

TABLE OF REPLACEABLE PARTS

CIRCUIT REF.	DESCRIPTION, MFR. * & MFR. DESIGNATION	Ⓢ STOCK NO.	#			
BOTTOM DECK (CONTINUED)						
V105	Tube, electron: 6J7	ZZ*	212-6J7	1		
V106	Tube, electron: 6F6	ZZ*	212-6F6	1		
V107	Tube, electron: OA2	ZZ*	212-OA2	1		
V108	Tube, electron: 6SQ7	ZZ*	212-6SQ7	1		
V109	Tube, electron: 6L6GB	ZZ*	212-6L6GB	1		
V110	Tube, electron: 5U4GA/B	ZZ*	212-5U4GA/ B	1		
MISCELLANEOUS						
	Binding Post Assembly: black	HP*	AC-10C	1		
	Binding Post Assembly: red	HP*	AC-10D	1		
	Coupler, insulated	HP*	M-25	1		
	Capacitor: assembly: tuning, complete	HP*	3A-7	1		
	Dial, blank: 7" diameter	HP*	3A-40	1		
	Drive, planetary:	Natl. Co.	149-11	1		
	Fuseholder	T*	140-16	1		
	Half bandwidth control	HP*	3A-15 B	1		
	Indicator, dial	HP*	M-25	1		
	Indicator Lamp Assembly	II*	145-2	1		
	Insulator, standoff: 1" x 3/8"	AI*	34-1	1		
	Knob: for control panel door	HP*	G-74C	1		
	Knob: engraved R	HP*	G-74AG	1		
	Knob: engraved C	HP*	G-74AH	1		
	Knob: engraved F	HP*	G-74AJ	1		
	Knob: engraved G	HP*	G-74AK	1		
	Knob: engraved V	HP*	G-74AL	1		
	Knob: engraved S (for lever switch)	HP*	G-74AM	1		

* See "List of Manufacturers Code Letters For Replaceable Parts Table".

Total quantity used in the instrument.

TABLE OF REPLACEABLE PARTS

CIRCUIT REF.	DESCRIPTION, MFR. * & MFR. DESIGNATION	Ⓟ STOCK NO.	#				
	MISCELLANEOUS (CONTINUED)						
	Knob: METER MULTIPLIER, METER SENSITIVITY	HP*	G-74N	2			
	Knob: VOLTAGE MEASUREMENT, FINE TUNING	HP*	G-74S	2			
	Knob: tuning, basic diameter, 2-3/4"	HP*	G-74Z	1			
	Knob: NEGATIVE FEEDBACK, HALF BAND WIDTH	HP*	G-74K	2			
	Lampholder: (for R40)	AD*	145-15	1			
	Label Set: "Calibrating Procedure" & "Operating Precautions"	HP*	712-271	1			
	Negative feedback control assembly	HP*	3A-15A	1			
	Washer, spring	HP*	3A-50	1			

* See "List of Manufacturers Code Letters For Replaceable Parts Table".

Total quantity used in the instrument.

SALES AND SERVICE OFFICES IN THE U.S. AND CANADA

ALABAMA

Huntsville, 35801
Hewlett-Packard
Southern Sales Division
Holiday Office Ctr., Suite 18
(205) 881-4591
TWX: 510-579-2204

ARIZONA

Scottsdale, 85251
Hewlett-Packard
Neely Sales Division
3009 No. Scottsdale Rd.
(602) 945-7601
TWX: 602-949-0111

Tucson, 85716
Hewlett-Packard
Neely Sales Division
232 So. Tucson Blvd.
(602) 623-2564
TWX: 602-792-2759

CALIFORNIA

Los Angeles Area
Hewlett-Packard
Neely Sales Division
3939 Lankershim Blvd.
North Hollywood 91604
(213) 877-1282 and 766-3811
TWX: 910-499-2170

Sacramento, 95821
Hewlett-Packard
Neely Sales Division
2591 Carlsbad Ave.
(916) 482-1463
TWX: 916-444-8683

San Diego, 92106
Hewlett-Packard
Neely Sales Division
1055 Shafter Street
(714) 223-8103
TWX: 714-276-4263

San Francisco Area
Hewlett-Packard
Neely Sales Division
501 Laurel Street
San Carlos 94071
(415) 591-7661
TWX: 910-376-4390

COLORADO

Englewood, 80110
Hewlett-Packard
Lahana Sales Division
7965 East Prentice
(303) 771-3455
TWX: 303-771-3056

CONNECTICUT

Middletown, 06458
Hewlett-Packard
Yewell Sales Division
589 Saybrook Rd.
(203) 346-6611
TWX: 203-346-7433

FLORIDA

Miami, 33125
Hewlett-Packard
Florida Sales Division
2907 Northwest 7th St.
(305) 635-6461

Orlando, 32803
Hewlett-Packard
Florida Sales Division
621 Commonwealth Ave.
(305) 425-5541
TWX: 305-275-1234

St. Petersburg, 33708
Hewlett-Packard
Florida Sales Division
410-150th Ave., Madeira Beach
(813) 391-0211
TWX: 813-391-0666

GEORGIA

Atlanta, 30305
Hewlett-Packard
Southern Sales Division
3110 Maple Drive, N. E.
(404) 233-1141
TWX: 810-751-3283

ILLINOIS

Chicago, 60645
Hewlett-Packard
Crossley Sales Division
2501 West Peterson Ave.
(312) 275-1600
TWX: 910-221-0277

INDIANA

Indianapolis, 46205
Hewlett-Packard
Crossley Sales Division
3919 Meadows Dr.
(317) 546-4891
TWX: 317-635-4300

KENTUCKY

Louisville, 40218
Hewlett-Packard
Southern Sales Division
Suite 4, 3411 Bardstown Rd.
(502) 459-4140
TWX: 810-535-3128

MARYLAND

Baltimore, 21207
Hewlett-Packard
Horman Sales Division
6660 Security Blvd.
(301) 944-5400

Washington, D. C. Area
Hewlett-Packard
Horman Sales Division
941 Rollins Avenue
Rockville 20852
(301) 427-7560
TWX: 710-828-9684

MASSACHUSETTS

Boston Area
Hewlett-Packard
Yewell Sales Division
Middlesex Turnpike
Burlington 01804
(617) 272-9000
TWX: 710-332-0382

MICHIGAN

Detroit, 48235
Hewlett-Packard
Crossley Sales Division
14425 West Eight Mile Road
(313) 342-5700
TWX: 313-342-0702

MINNESOTA

St. Paul, 55114
Hewlett-Packard
Crossley Sales Division
842 Raymond Avenue
(612) 646-7881
TWX: 612-551-0055

MISSOURI

Kansas City, 64131
Harris-Hanson Company
7916 Paseo Street
(816) 444-9494
TWX: 816-556-2423

St. Louis, 63144
Harris-Hanson Company
2814 South Brentwood Blvd.
(314) 647-4350
TWX: 314-962-3933

NEW JERSEY

Asbury Park Area
Hewlett-Packard
Robinson Sales Division
Shrewsbury
(201) 747-1060

Englewood, 07631
Hewlett-Packard
RMC Sales Division
391 Grand Avenue
(201) 567-3933

NEW MEXICO

Albuquerque, 87108
Hewlett-Packard
Neely Sales Division
6501 Lomas Blvd., N. E.
(505) 255-5586
TWX: 505-243-8314

Las Cruces, 88001
Hewlett-Packard
Neely Sales Division
114 S. Water Street
(505) 526-2486
TWX: 505-524-2671

NEW YORK

New York, 10021
Hewlett-Packard
RMC Sales Division
236 East 75th Street
(212) 879-2023
TWX: 710-581-4376

Rochester, 14625
Hewlett-Packard
Syracuse Sales Division
800 Linden Avenue
(716) 381-4120
TWX: 716-221-1514

Poughkeepsie, 12601
Hewlett-Packard
Syracuse Sales Division
82 Washington St.
(914) 454-7330
TWX: 914-452-7425

Syracuse, 13211
Hewlett-Packard
Syracuse Sales Division
Pickard Bldg., E. Molloy Rd.
(315) 454-2486
TWX: 315-477-1375

NORTH CAROLINA

High Point, 27262
Hewlett-Packard
Southern Sales Division
1923 N. Main Street
(919) 882-6873
TWX: 510-926-1516

OHIO

Cleveland, 44129
Hewlett-Packard
Crossley Sales Division
5579 Pearl Road
(216) 884-9209
TWX: 216-888-0715

Dayton, 45409
Hewlett-Packard
Crossley Sales Division
1250 W. Dorothy Lane
(513) 299-3594
TWX: 513-944-0090

PENNSYLVANIA

Camp Hill
Hewlett-Packard
Robinson Sales Division
(717) 737-6791

Philadelphia Area
Hewlett-Packard
Robinson Sales Division
144 Elizabeth Street
West Conshohocken 19428
(215) 248-1600 and 828-6200
TWX: 215-828-3847

Pittsburgh Area
Hewlett-Packard
Crossley Sales Division
2545 Moss Side Blvd.
Monroeville 15146
(412) 271-5227
TWX: 710-797-3650

TEXAS

Dallas, 75209
Hewlett-Packard
Southwest Sales Division
P.O. Box 7166, 3605 Inwood Rd.
(214) 357-1881 and 332-6667
TWX: 910-861-4081

Houston, 77027
Hewlett-Packard
Southwest Sales Division
P.O. Box 22813, 4242 Richmond Ave.
(713) 667-2407
TWX: 713-571-1353

UTAH

Salt Lake City, 84115
Hewlett-Packard
Lahana Sales Division
1482 Major St.
(801) 486-8166
TWX: 801-521-2604

VIRGINIA

Richmond, 23230
Hewlett-Packard
Southern Sales Division
2112 Spencer Road
(703) 282-5451
TWX: 703-282-9986

WASHINGTON

Seattle Area
Hewlett-Packard
Neely Sales Division
11656 N. E. 8th St.
Bellevue 98004
(206) GL4-3971
TWX: 910-443-2303

CANADA

Montreal, Quebec
Hewlett-Packard (Canada) Ltd.
8270 Mayrand Street
(514) 735-2273
TWX: 610-421-3484

Ottawa, Ontario
Hewlett-Packard (Canada) Ltd.
1762 Carling Avenue
(613) 722-4223
TWX: 610-562-1952

Toronto, Ontario
Hewlett-Packard (Canada) Ltd.
1415 Lawrence Avenue, West
(416) 249-9196
TWX: 610-492-2382

HEWLETT  PACKARD

INTERNATIONAL SALES AND SERVICE OFFICES

ARGENTINA

Mauricio A. Saurez
Telecomunicaciones
Carlos Calvo 224, Buenos Aires
Tel: 30-6312

AUSTRALIA

Sample Electronics (Vic.) Pty. Ltd.
9-11 Cremorne Street
Richmond E. 1, Victoria
Tel: 42-4757 (3 lines)
Sample Electronics (N.S.W.) Pty. Ltd.
4 Grose Street, Glebe, Sydney
New South Wales
Tel: 69-6338 (6 lines)

AUSTRIA

Unilabor G.m.b.H.
Rummelhardtgasse 6/3
Vienna
Tel: 426.181

BELGIUM

Hewlett-Packard Benelux S.A.
20-24 Rue de l'Hopital, Brussels
Tel: 11.22.20

BRAZIL

Ciental Importacao E Comercio Ltda.
Rua Cons. Crispiniano, 69, 8. ° And.,
Conj. 81, Sao Paulo
Tel: 32-4332

CANADA

Hewlett-Packard (Canada) Ltd.
8270 Mayrand Street
Montreal, Quebec
(514) 735-2273
Hewlett-Packard (Canada) Ltd.
1762 Carling Avenue
Ottawa, Ontario
(613) 722-8162
Hewlett-Packard (Canada) Ltd.
1415 Lawrence Avenue W.
Toronto, Ontario
(416) 249-9196

CHILE

Hector Calcagni
Casilla 13942
Santiago
Tel: 6.42.26

DENMARK

Tage Olsen A/S
Ronnegade 1
Copenhagen Ø
Tel: 29.48.00

FINLAND

INTO O/Y
P. O. Box 153
Meritullinkatu 11, Helsinki
Tel: 66.39.09 and 35.125

FRANCE

Hewlett-Packard France
150 Boulevard Massena
Paris 13e
Tel: 707.97.19

GERMANY

Hewlett-Packard V.m.b.H.
Steindamm 35, Hamburg
Tel: 24.05.51
Hewlett-Packard V.m.b.H.
Kurfürstenstrasse 95
Frankfurt am Main
Tel: 52.00.36

Hewlett-Packard V.m.b.H.
Reginfriedstrasse 13
Munich 9
Tel: 49.51.21.22

Hewlett-Packard V.m.b.H.
Technisches Büro
Herrenbergerstrasse 110
703 Böblingen, Württemberg
Tel: 6971

GREECE

K. Karayannis
Klaffmonos Square, Athens 124
Tel: 230.301 (5 lines)

INDIA

The Scientific Instrument Company, Ltd.
6, Tej Bahadur Sapru Road, Allahabad 1
Tel: 2451
The Scientific Instrument Company, Ltd.
240, Dr. Dadabhai Naoroji Road,
Bombay 1
Tel: 26-2642
The Scientific Instrument Company, Ltd.
11, Esplanade East, Calcutta 1
Tel: 23-4129
The Scientific Instrument Company, Ltd.
30, Mount Road, Madras 2
Tel: 86339
The Scientific Instrument Company, Ltd.
B-7, Ajmeri Gate Extn., New Delhi 1
Tel: 271053

IRAN

Telecom Ltd.
P. O. Box 1812, Tehran
Tel: 43850, 48111

ISRAEL

Electronics & Engineering Ltd.
16 Kremenetski St., Tel Aviv
Tel: 35021 (3 lines)

ITALY

Hewlett-Packard Italiana S.p.A.
Viale Lunigiana 46, Milan
Tel: 69.15.84/5/6
Hewlett-Packard Italiana S.p.A.
Piazza Marconi, 25
Roma-Eur
Tel: 59.25.44/5

JAPAN

Yokogawa-Hewlett-Packard Ltd.
2270 Ishikawa-cho
Hachioji, Tokyo
Tel: Hachioji 0426-3-1231 (19 lines)
Yokogawa-Hewlett-Packard Ltd.
No. 3, 6-chome, Aoyama-Kitamachi
Akasaka, Minato-ku, Tokyo
Tel: 403-0073, 403-0074, 403-0075
Yokogawa-Hewlett-Packard Ltd.
No. 8, Umeda, Kita-ku, Osaka City
Tel: 361-3084, 341-2095
Yokogawa-Hewlett-Packard Ltd.
No. 4, 3-chome, Himekedori,
Chigusa-ku, Nagoya City
Tel: 75-8545

KOREA

American Trading Company, Korea, Ltd.
112-35 Sokong-Dong
Seoul P. O. Box 1103
Seoul
Tel: 3-7049, 3-7613

NETHERLANDS

Hewlett-Packard Benelux N.V.
23 Burg Roellstraat, Amsterdam W.
Tel: (020) 13.28.98 and 13.54.99

NEW ZEALAND

Sample Electronics (N. Z.) Ltd.
8 Matipo Street
Onehunga S. E. 5, Auckland
Tel: 565-361

NORWAY

Morgenstjerne & Co. A/S
Ingeniørfirma
6 Wessels Gate, Oslo
Tel: 20 16 35

PORTUGAL

Telectra
Rua Rodrigo da Fonseca 103
P. O. Box 2531
Lisbon 1
Tel: 68 60 72 and 68 60 73 and 68 60 74

PUERTO RICO & VIRGIN ISLANDS

San Juan Electronics, Inc.
150 Ponce de Leon, Stop 3
P. O. Box 5167
Pta. de Tierra Sta., San Juan 00906
Tel: 722-3342, 724-4406

SPAIN

ATAIO, Ingenieros
A. Aguilera, No. 8, Madrid 15
Tel: 223.27.42, 223.41.71, and 224.84.97

SOUTH AFRICA

F. H. Flanter & Co. (Pty.), Ltd.
Rosella House
Buitencingle Street, Cape Town
Tel: 3-3817

SWEDEN

H-P Instrument AB
Centralvagen 28, Solna Centrum
Tel: 08-83.08.30 and 10-83.08.30

SWITZERLAND

Max Pual Frey
Wankdorffeldstrasse 66, Bern
Tel: (031) 42.00.78

TAIWAN (FORMOSA)

Hwa Sheng Electronic Co., Ltd.
21 Nanking West Road, Taipei
Tel: 4-6076, 4-5936

TURKEY

TELEKOM Engineering Bureau
P.O. Box 376—Galata, Istanbul
Tel: 49.40.40

UNITED KINGDOM

Hewlett-Packard Ltd.
Dallas Road
Bedford, England
Tel: Bedford 68052

VENEZUELA

Citec, C. A.
Edif. Arisan-Of #4
Avda. Francisco de Miranda-Chacaito
Apartado del Este 10.837, Caracas
Tel: 71.88.05

YUGOSLAVIA

Belram S.A.
83 Av. des Mimosas
Brussels 15, Belgium
Tel: 35.29.58

For Sales and Service Assistance in Areas Not Listed Contact:

IN EUROPE

Hewlett-Packard, S. A.
54 Route des Acacias
Geneva, Switzerland
Telephone: (022) 42.81.50
Telex: 2 24.86
Cable: HEWPACKSA

IN LATIN AMERICA

Hewlett-Packard Inter-Americas
1501 Page Mill Road
Palo Alto, California 94304, U.S.A.
Telephone: (415) 326-7000
TWX: 910-373-1267
Telex: 033811 Cable: HEWPACK

ELSEWHERE

Hewlett-Packard
International Marketing Department
1501 Page Mill Road
Palo Alto, California 94304, U.S.A.
Telephone: (415) 326-7000
TWX: 910-373-1267
Telex: 033811 Cable: HEWPACK

SALES AND SERVICE OFFICES IN THE U.S. AND CANADA

ALABAMA

Huntsville, 35801
Hewlett-Packard
Southern Sales Division
Holiday Office Ctr., Suite 18
(205) 881-4591
TWX: 510-579-2204

ARIZONA

Scottsdale, 85251
Hewlett-Packard
Neely Sales Division
3009 No. Scottsdale Rd.
(602) 945-7601
TWX: 602-949-0111

Tucson, 85716
Hewlett-Packard
Neely Sales Division
232 So. Tucson Blvd.
(602) 623-2564
TWX: 602-792-2759

CALIFORNIA

Los Angeles Area
Hewlett-Packard
Neely Sales Division
3939 Lankershim Blvd.
North Hollywood 91604
(213) 877-1282 and 766-3811
TWX: 910-499-2170

Sacramento, 95821
Hewlett-Packard
Neely Sales Division
2591 Carlsbad Ave.
(916) 482-1463
TWX: 916-444-8683

San Diego, 92106
Hewlett-Packard
Neely Sales Division
1055 Shafter Street
(714) 223-8103
TWX: 714-276-4263

San Francisco Area
Hewlett-Packard
Neely Sales Division
501 Laurel Street
San Carlos 94071
(415) 591-7661
TWX: 910-376-4390

COLORADO

Englewood, 80110
Hewlett-Packard
Lahana Sales Division
7965 East Prentice
(303) 771-3455
TWX: 303-771-3056

CONNECTICUT

Middletown, 06458
Hewlett-Packard
Yewell Sales Division
589 Saybrook Rd.
(203) 346-6611
TWX: 203-346-7433

FLORIDA

Miami, 33125
Hewlett-Packard
Florida Sales Division
2907 Northwest 7th St.
(305) 635-6461

Orlando, 32803
Hewlett-Packard
Florida Sales Division
621 Commonwealth Ave.
(305) 425-5541
TWX: 305-275-1234

St. Petersburg, 33708
Hewlett-Packard
Florida Sales Division
410-150th Ave., Madeira Beach
(813) 391-0211
TWX: 813-391-0666

GEORGIA

Atlanta, 30305
Hewlett-Packard
Southern Sales Division
3110 Maple Drive, N. E.
(404) 233-1141
TWX: 810-751-3283

ILLINOIS

Chicago, 60645
Hewlett-Packard
Crossley Sales Division
2501 West Peterson Ave.
(312) 275-1600
TWX: 910-221-0277

INDIANA

Indianapolis, 46205
Hewlett-Packard
Crossley Sales Division
3919 Meadows Dr.
(317) 546-4891
TWX: 317-635-4300

KENTUCKY

Louisville, 40218
Hewlett-Packard
Southern Sales Division
Suite 4, 3411 Bardstown Rd.
(502) 459-4140
TWX: 810-535-3128

MARYLAND

Baltimore, 21207
Hewlett-Packard
Horman Sales Division
6660 Security Blvd.
(301) 944-5400

Washington, D. C. Area
Hewlett-Packard
Horman Sales Division
941 Rollins Avenue
Rockville 20852
(301) 427-7560
TWX: 710-828-9684

MASSACHUSETTS

Boston Area
Hewlett-Packard
Yewell Sales Division
Middlesex Turnpike
Burlington 01804
(617) 272-9000
TWX: 710-332-0382

MICHIGAN

Detroit, 48235
Hewlett-Packard
Crossley Sales Division
14425 West Eight Mile Road
(313) 342-5700
TWX: 313-342-0702

MINNESOTA

St. Paul, 55114
Hewlett-Packard
Crossley Sales Division
842 Raymond Avenue
(612) 646-7881
TWX: 612-551-0055

MISSOURI

Kansas City, 64131
Harris-Hanson Company
7916 Paseo Street
(816) 444-9494
TWX: 816-556-2423

St. Louis, 63144
Harris-Hanson Company
2814 South Brentwood Blvd.
(314) 647-4350
TWX: 314-962-3933

NEW JERSEY

Asbury Park Area
Hewlett-Packard
Robinson Sales Division
Shrewsbury
(201) 747-1060

Englewood, 07631
Hewlett-Packard
RMC Sales Division
391 Grand Avenue
(201) 567-3933

NEW MEXICO

Albuquerque, 87108
Hewlett-Packard
Neely Sales Division
6501 Lomas Blvd., N. E.
(505) 255-5586
TWX: 505-243-8314

Las Cruces, 88001
Hewlett-Packard
Neely Sales Division
114 S. Water Street
(505) 526-2486
TWX: 505-524-2671

NEW YORK

New York, 10021
Hewlett-Packard
RMC Sales Division
236 East 75th Street
(212) 879-2023
TWX: 710-581-4376

Rochester, 14625
Hewlett-Packard
Syracuse Sales Division
800 Linden Avenue
(716) 381-4120
TWX: 716-221-1514

Poughkeepsie, 12601
Hewlett-Packard
Syracuse Sales Division
82 Washington St.
(914) 454-7330
TWX: 914-452-7425

Syracuse, 13211
Hewlett-Packard
Syracuse Sales Division
Pickard Bldg., E. Molloy Rd.
(315) 454-2486
TWX: 315-477-1375

NORTH CAROLINA

High Point, 27262
Hewlett-Packard
Southern Sales Division
1923 N. Main Street
(919) 882-6873
TWX: 510-926-1516

OHIO

Cleveland, 44129
Hewlett-Packard
Crossley Sales Division
5579 Pearl Road
(216) 884-9209
TWX: 216-888-0715

Dayton, 45409
Hewlett-Packard
Crossley Sales Division
1250 W. Dorothy Lane
(513) 299-3594
TWX: 513-944-0090

PENNSYLVANIA

Camp Hill
Hewlett-Packard
Robinson Sales Division
(717) 737-6791

Philadelphia Area
Hewlett-Packard
Robinson Sales Division
144 Elizabeth Street
West Conshohocken 19428
(215) 248-1600 and 828-6200
TWX: 215-828-3847

Pittsburgh Area
Hewlett-Packard
Crossley Sales Division
2545 Moss Side Blvd.
Monroeville 15146
(412) 271-5227
TWX: 710-797-3650

TEXAS

Dallas, 75209
Hewlett-Packard
Southwest Sales Division
P.O. Box 7166, 3605 Inwood Rd.
(214) 357-1881 and 332-6667
TWX: 910-861-4081

Houston, 77027
Hewlett-Packard
Southwest Sales Division
P.O. Box 22813, 4242 Richmond Ave.
(713) 667-2407
TWX: 713-571-1353

UTAH

Salt Lake City, 84115
Hewlett-Packard
Lahana Sales Division
1482 Major St.
(801) 486-8166
TWX: 801-521-2604

VIRGINIA

Richmond, 23230
Hewlett-Packard
Southern Sales Division
2112 Spencer Road
(703) 282-5451
TWX: 703-282-9986

WASHINGTON

Seattle Area
Hewlett-Packard
Neely Sales Division
11656 N. E. 8th St.
Bellevue 98004
(206) 614-3971
TWX: 910-443-2303

CANADA

Montreal, Quebec
Hewlett-Packard (Canada) Ltd.
8270 Mayrand Street
(514) 735-2273
TWX: 610-421-3484

Ottawa, Ontario
Hewlett-Packard (Canada) Ltd.
1762 Carling Avenue
(613) 722-4223
TWX: 610-562-1952

Toronto, Ontario
Hewlett-Packard (Canada) Ltd.
1415 Lawrence Avenue, West
(416) 249-9196
TWX: 610-492-2382

HEWLETT  PACKARD

INTERNATIONAL SALES AND SERVICE OFFICES

ARGENTINA

Mauricio A. Saurez
Telecomunicaciones
Carlos Calvo 224, Buenos Aires
Tel: 30-6312

AUSTRALIA

Sample Electronics (Vic.) Pty. Ltd.
9-11 Cremorne Street
Richmond E. 1, Victoria
Tel: 42-4757 (3 lines)
Sample Electronics (N.S.W.) Pty. Ltd.
4 Grose Street, Glebe, Sydney
New South Wales
Tel: 69-6338 (6 lines)

AUSTRIA

Unilabor G.m.b.H.
Rummelhardtgasse 6/3
Vienna
Tel: 426.181

BELGIUM

Hewlett-Packard Benelux S.A.
20-24 Rue de l'Hopital, Brussels
Tel: 11.22.20

BRAZIL

Ciental Importacao E Comercio Ltda.
Rua Cons. Crispiniano, 69, 8. ° And.,
Conj. 81, Sao Paulo
Tel: 32-4332

CANADA

Hewlett-Packard (Canada) Ltd.
8270 Mayrand Street
Montreal, Quebec
(514) 735-2273
Hewlett-Packard (Canada) Ltd.
1762 Carling Avenue
Ottawa, Ontario
(613) 722-8162
Hewlett-Packard (Canada) Ltd.
1415 Lawrence Avenue W.
Toronto, Ontario
(416) 249-9196

CHILE

Hector Calcagni
Casilla 13942
Santiago
Tel: 6.42.26

DENMARK

Tage Olsen A/S
Ronnegade 1
Copenhagen Ø
Tel: 29.48.00

FINLAND

INTO O/Y
P. O. Box 153
Meritulinkatu 11, Helsinki
Tel: 66.39.09 and 35.125

FRANCE

Hewlett-Packard France
150 Boulevard Massena
Paris 13e
Tel: 707.97.19

GERMANY

Hewlett-Packard V.m.b.H.
Steindamm 35, Hamburg
Tel: 24.05.51
Hewlett-Packard V.m.b.H.
Kurhessenstrasse 95
Frankfurt am Main
Tel: 52.00.36

Hewlett-Packard V.m.b.H.
Reginfriedstrasse 13
Munich 9
Tel: 49.51.21/22

Hewlett-Packard V.m.b.H.
Technisches Büro
Herrenbergerstrasse 110
703 Böblingen, Württemberg
Tel: 6971

GREECE

K. Karayannis
Klaffmonos Square, Athens 124
Tel: 230.301 (5 lines)

INDIA

The Scientific Instrument Company, Ltd.
6, Tej Bahadur Sapru Road, Allahabad 1
Tel: 2451

The Scientific Instrument Company, Ltd.
240, Dr. Dadabhai Naoroji Road,
Bombay 1
Tel: 26-2642

The Scientific Instrument Company, Ltd.
11, Esplanade East, Calcutta 1
Tel: 23-4129

The Scientific Instrument Company, Ltd.
30, Mount Road, Madras 2
Tel: 86339

The Scientific Instrument Company, Ltd.
B-7, Ajmeri Gate Extn., New Delhi 1
Tel: 271053

IRAN

Telecom Ltd.
P. O. Box 1812, Tehran
Tel: 43850, 48111

ISRAEL

Electronics & Engineering Ltd.
16 Kremenetski St., Tel Aviv
Tel: 35021 (3 lines)

ITALY

Hewlett-Packard Italiana S.p.A.
Viale Lunigiana 46, Milan
Tel: 69.15.84/5/6

Hewlett-Packard Italiana S.p.A.
Piazza Marconi, 25
Roma-Eur
Tel: 59.25.44/5

JAPAN

Yokogawa-Hewlett-Packard Ltd.
2270 Ishikawa-cho
Hachioji, Tokyo
Tel: Hachioji 0426-3-1231 (19 lines)

Yokogawa-Hewlett-Packard Ltd.
No. 3, 6-chome, Aoyama-Kitamachi
Akasaka, Minato-ku, Tokyo
Tel: 403-0073, 403-0074, 403-0075

Yokogawa-Hewlett-Packard Ltd.
No. 8, Umeda, Kita-ku, Osaka City
Tel: 361-3084, 341-2095

Yokogawa-Hewlett-Packard Ltd.
No. 4, 3-chome, Himeikedori,
Chigusa-ku, Nagoya City
Tel: 75-8545

KOREA

American Trading Company, Korea, Ltd.
112-35 Sokong-Dong
Seoul P. O. Box 1103
Seoul
Tel: 3-7049, 3-7613

NETHERLANDS

Hewlett-Packard Benelux N.V.
23 Burg Roellstraat, Amsterdam W.
Tel: (020) 13.28.98 and 13.54.99

NEW ZEALAND

Sample Electronics (N. Z.) Ltd.
8 Matipo Street
Onehunga S. E. 5, Auckland
Tel: 565-361

NORWAY

Morgenstjerne & Co. A/S
Ingeniørfirma
6 Wessels Gate, Oslo
Tel: 20 16 35

PORTUGAL

Telectra
Rua Rodrigo da Fonseca 103
P. O. Box 2531
Lisbon 1
Tel: 68 60 72 and 68 60 73 and 68 60 74

PUERTO RICO & VIRGIN ISLANDS

San Juan Electronics, Inc.
150 Ponce de Leon, Stop 3
P. O. Box 5167
Pta. de Tierra Sta., San Juan 00906
Tel: 722-3342, 724-4406

SPAIN

ATAIO, Ingenieros
A. Aguilera, No. 8, Madrid 15
Tel: 223.27.42, 223.41.71, and 224.84.97

SOUTH AFRICA

F. H. Flanter & Co. (Pty.), Ltd.
Rosella House
Buitencingle Street, Cape Town
Tel: 3-3817

SWEDEN

H-P Instrument AB
Centralvagen 28, Solna Centrum
Tel: 08-83.08.30 and 10-83.08.30

SWITZERLAND

Max Pual Frey
Wankdorffeldstrasse 66, Bern
Tel: (031) 42.00.78

TAIWAN (FORMOSA)

Hwa Sheng Electronic Co., Ltd.
21 Nanking West Road, Taipei
Tel: 4-6076, 4-5936

TURKEY

TELEKOM Engineering Bureau
P.O. Box 376—Galata, Istanbul
Tel: 49.40.40

UNITED KINGDOM

Hewlett-Packard Ltd.
Dallas Road
Bedford, England
Tel: Bedford 68052

VENEZUELA

Citec, C. A.
Edif. Arisan-Of #4
Avda. Francisco de Miranda-Chacaito
Apartado del Este 10.837, Caracas
Tel: 71.88.05

YUGOSLAVIA

Belram S.A.
83 Av. des Mimosas
Brussels 15, Belgium
Tel: 35.29.58

For Sales and Service Assistance in Areas Not Listed Contact:

IN EUROPE

Hewlett-Packard, S. A.
54 Route des Acacias
Geneva, Switzerland
Telephone: (022) 42.81.50
Telex: 2.24.86
Cable: HEWPACKSA

IN LATIN AMERICA

Hewlett-Packard Inter-Américas
1501 Page Mill Road
Palo Alto, California 94304, U.S.A.
Telephone: (415) 326-7000
TWX: 910-373-1267
Telex: 033811 Cable: HEWPACK

ELSEWHERE

Hewlett-Packard
International Marketing Department
1501 Page Mill Road
Palo Alto, California 94304, U.S.A.
Telephone: (415) 326-7000
TWX: 910-373-1267
Telex: 033811 Cable: HEWPACK

CERTIFICATION

The Hewlett-Packard Company certifies that this instrument was thoroughly tested and inspected and found to meet its published specifications when it was shipped from the factory. The Hewlett-Packard Company further certifies that its calibration measurements are traceable to the U.S. National Bureau of Standards to the extent allowed by the Bureau's calibration facility.

WARRANTY AND ASSISTANCE

All Hewlett-Packard products are warranted against defects in materials and workmanship. This warranty applies for one year from the date of delivery, or, in the case of certain major components listed in the operating manual, for the specified period. We will repair or replace products which prove to be defective during the warranty period. No other warranty is expressed or implied. We are not liable for consequential damages.

For any assistance contact your nearest Hewlett-Packard Sales and Service Office. Addresses are provided at the back of this manual.